

TL20/4

Codice testa
Head code

Codice mandrino
Spindle code



N° prese di moto
Nr. spindle drives

08



Rapporto
Ratio

1-1



Capacità di foratura
Drilling capacity
acciaio R=500 N/mm²
ghisa: GG25

4

5

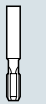

Maschiatura
Tapping

M4



Attacco utensile
Type of spindle
P

ER11



Peso gruppo testa
Head weight

Kg 13,5



Peso gruppo mandrino
Spindle-set weight

Kg 1

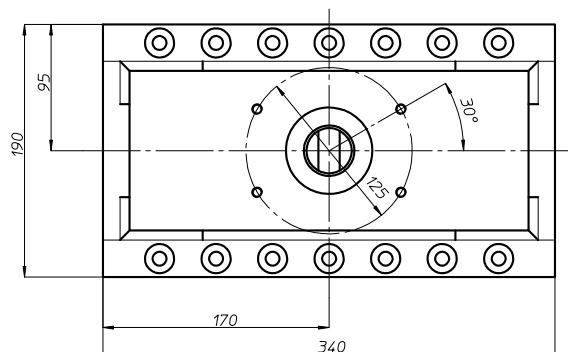
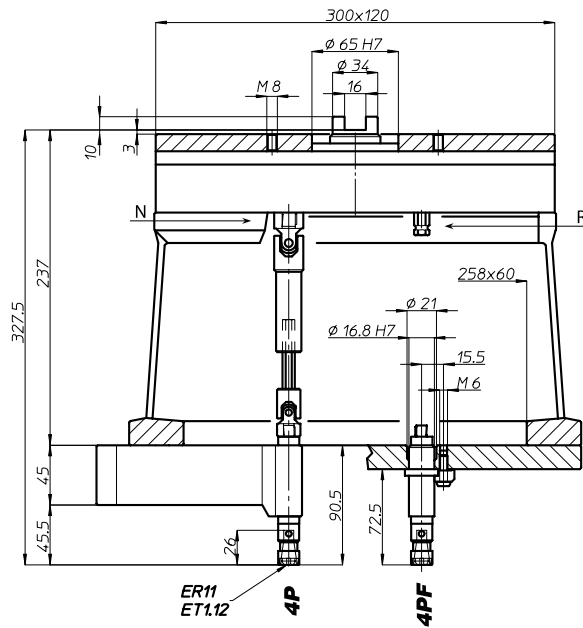
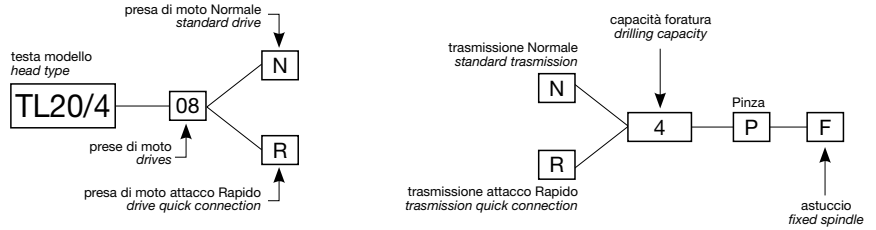

area di lavoro
working area

