

TL20/6

Codice testa
Head code

Codice mandrino
Spindle code

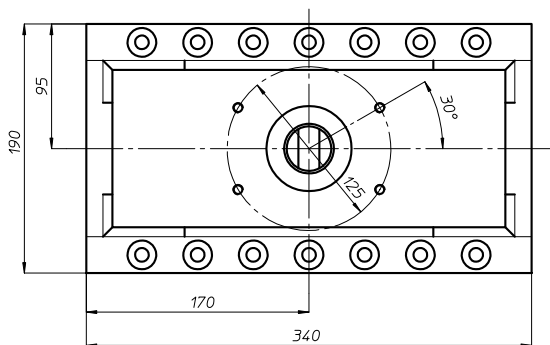
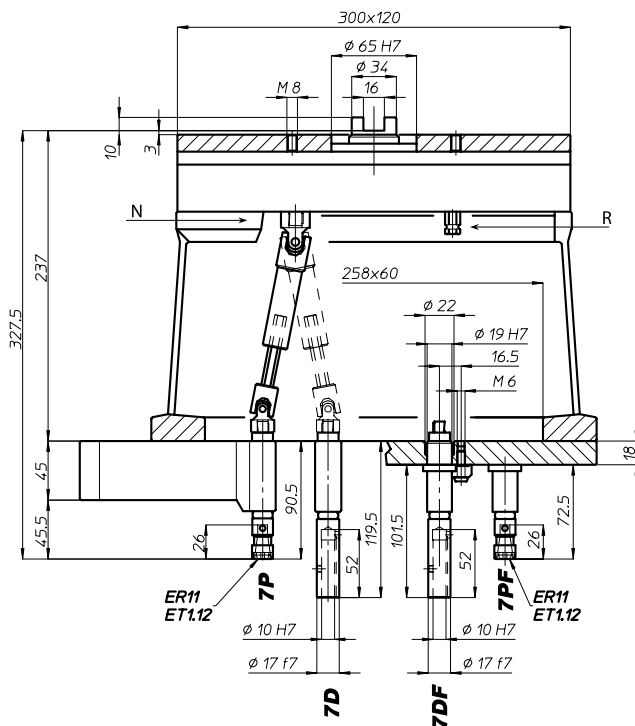
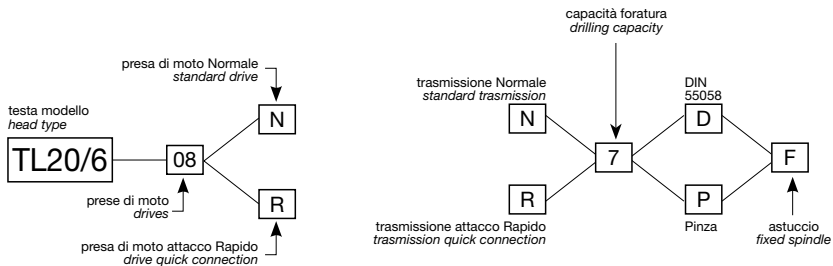

	N° prese di moto Nr. spindle drives	08
	Rapporto Ratio	1-1
	Capacità di foratura Drilling capacity acciaio R=500 N/mm ² ghisa: GG25	6 7
	Maschiatura Tapping	M5
	Attacco utensile Type of spindle D P	DIN 55058 Ø10 ER11
	Peso gruppo testa Head weight	Kg 13,5
	Peso gruppo mandrino Spindle-set weight	Kg 1

area di lavoro
working area

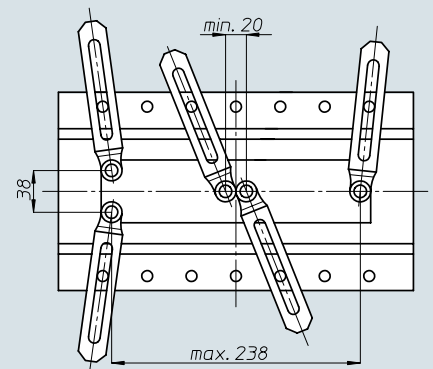

FH

BAH

TA.CP

TA

MO

HT

VH

TSI/TSX

T

MT-TC-TC3

Accessori
Accessories

Appendice tecnica
Technical supplement