

TL20/8

Codice testa
Head code

Codice mandrino
Spindle code



N° prese di moto
Nr. spindle drives

08



Rapporto
Ratio

1-1



Capacità di foratura
Drilling capacity
acciaio R=500 N/mm²
ghisa: GG25

8
10

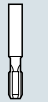

Maschiatura
Tapping

M6



Attacco utensile
Type of spindle

DIN 55058 Ø12
ER16



Peso gruppo testa
Head weight

Kg 13,5



Peso gruppo mandrino
Spindle-set weight

Kg 1,5

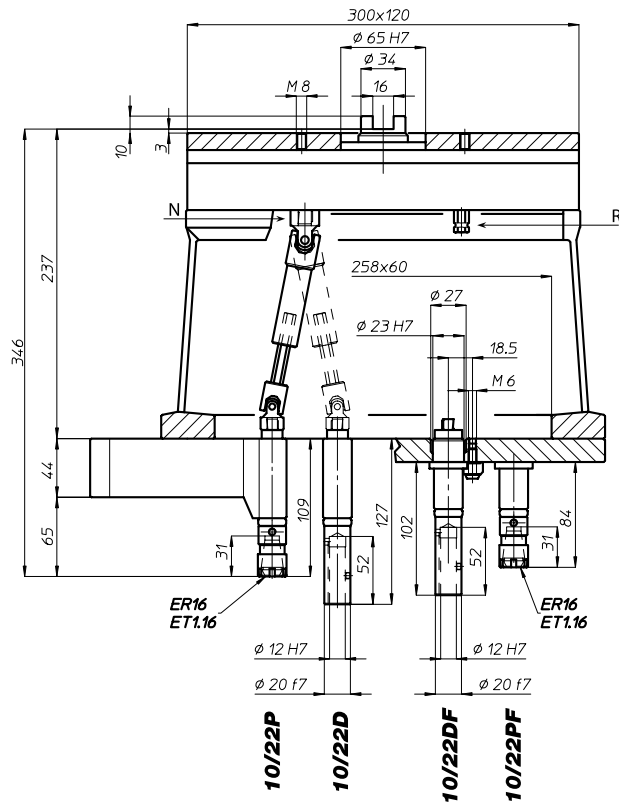
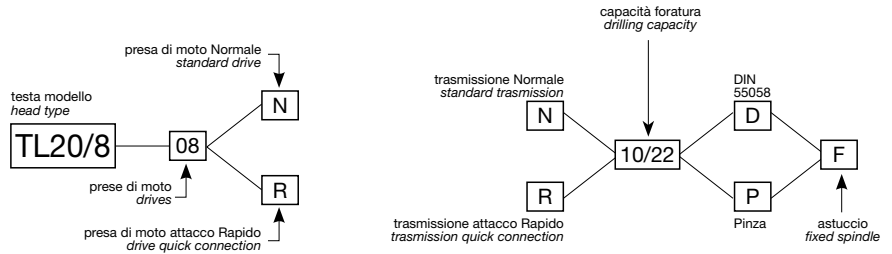

area di lavoro
working area

