

TL40/16



Codice testa
Head code

Codice mandrino
Spindle code



N° prese di moto
Nr. spindle drives

08



Rapporto
Ratio

1-1



Capacità di foratura
Drilling capacity
acciaio R=500 N/mm²
ghisa: GG25

16

18

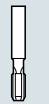

Maschiatura
Tapping

M14



Attacco utensile
Type of spindle
D

DIN 55058 Ø25



Peso gruppo testa
Head weight

Kg 26



Peso gruppo mandrino
Spindle-set weight

Kg 2,5

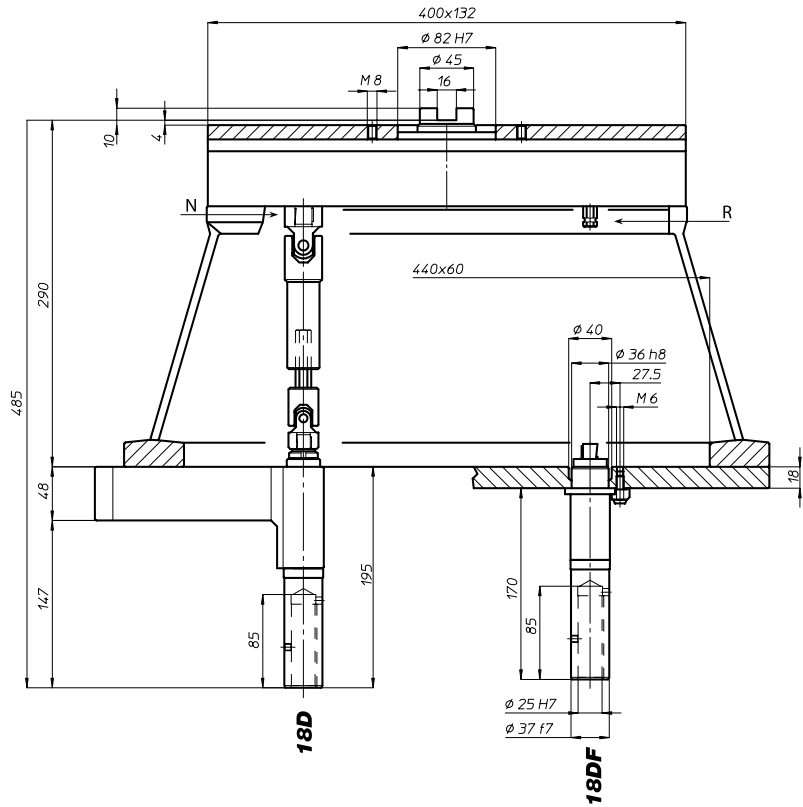
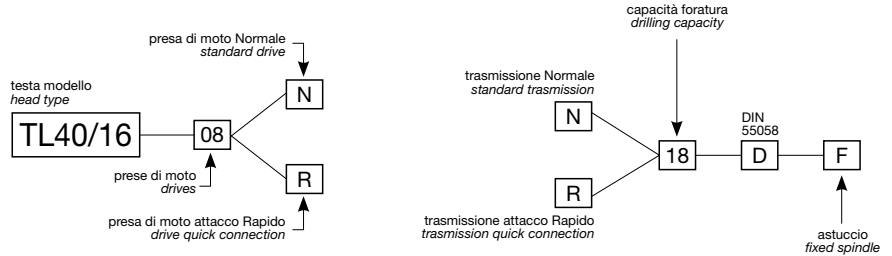

area di lavoro
working area

