

# TL60/16

Codice testa  
Head code

Codice mandrino  
Spindle code

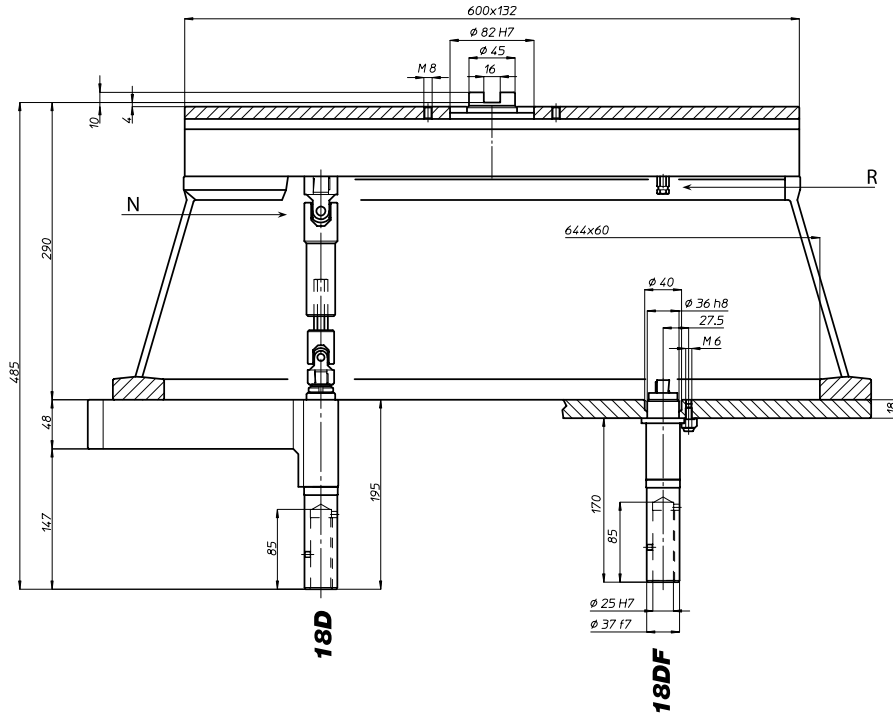
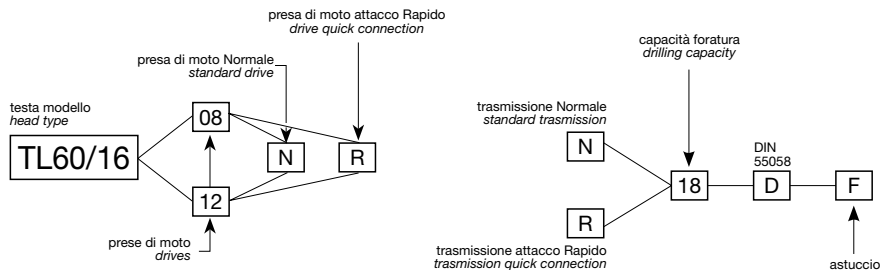

N° prese di moto  
Nr. spindle drives

08-12



Rapporto  
Ratio

1-1



Capacità di foratura  
Drilling capacity  
acciaio R=500 N/mm<sup>2</sup>  
ghisa: GG25

MO

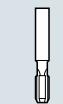

Maschiatura  
Tapping

M14



Attacco utensile  
Type of spindle  
D

DIN 55058  $\phi 25$

HT



Peso gruppo testa  
Head weight

Kg 36

VH



Peso gruppo mandrino  
Spindle-set weight

Kg 2,5

TSI/TSX

area di lavoro  
working area

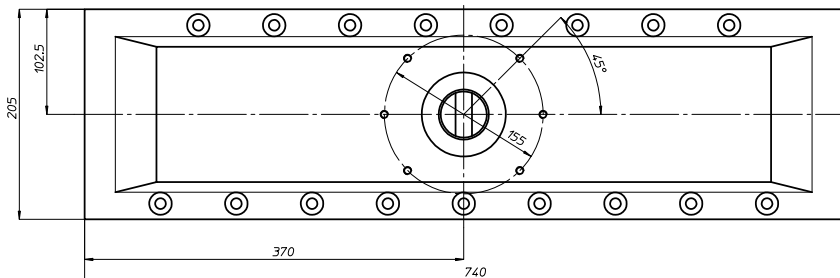
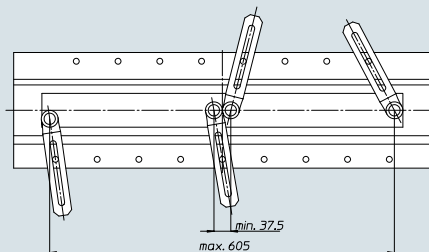

FH

BAH

TA.CP

TA

MO

HT

VH

TSI/TSX

T

MT-TC-TC3

Accessori  
Accessories

Appendice tecnica  
Technical supplement