

TR2/12

Codice testa
Head code

Codice mandrino
Spindle code

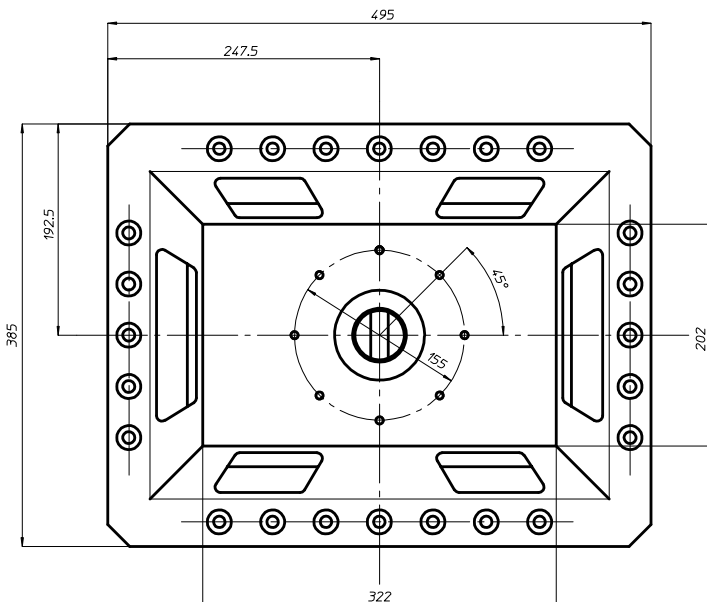
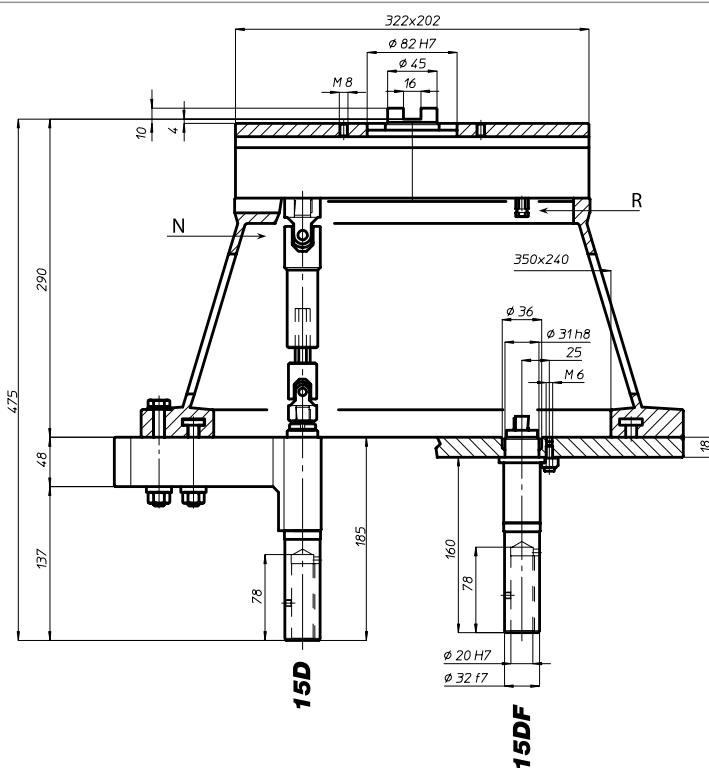
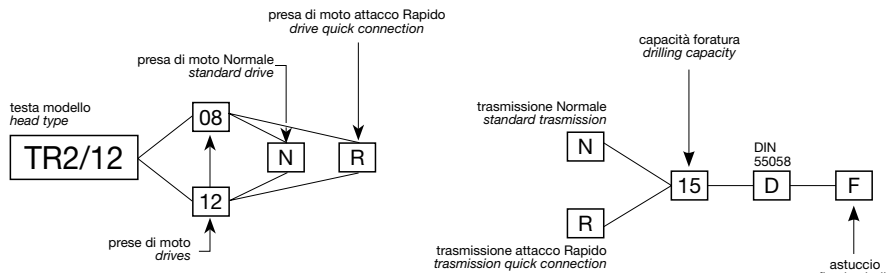

	N° prese di moto Nr. spindle drives	08-12
	Rapporto Ratio	1-1
	Capacità di foratura Drilling capacity acciaio R=500 N/mm ² ghisa: GG25	13 15
	Maschiatura Tapping	M12
	Attacco utensile Type of spindle D	DIN 55058 Ø20
	Peso gruppo testa Head weight	Kg 30
	Peso gruppo mandrino Spindle-set weight	Kg 2,6

area di lavoro
working area

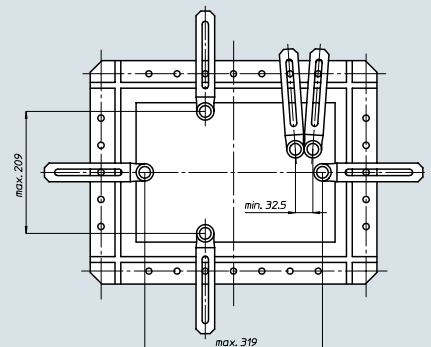

FH

BAH

TA.CP

TA

MO

HT

VH

TSI/TSX

T

MT-TC-TC3

Accessori
Accessories

Appendice tecnica
Technical supplement