

TR2/16

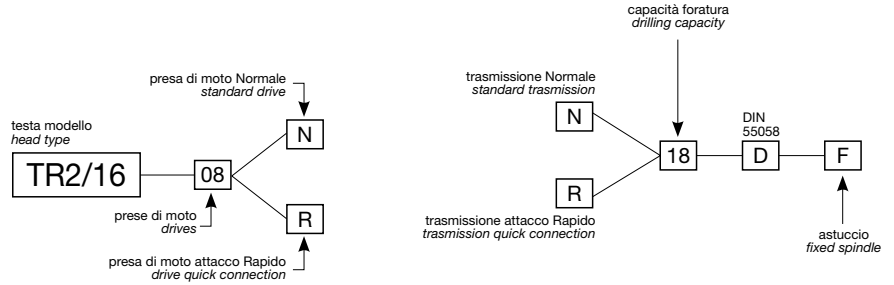

Codice testa
Head code

Codice mandrino
Spindle code



N° prese di moto
Nr. spindle drives

10



Rapporto
Ratio

1-1



Capacità di foratura
Drilling capacity
acciaio R=500 N/mm²
ghisa: GG25

16
18



Maschiatura
Tapping

M14



Attacco utensile
Type of spindle

D DIN 55058 Ø25



Peso gruppo testa
Head weight

Kg 31



Peso gruppo mandrino
Spindle-set weight

Kg 3,3

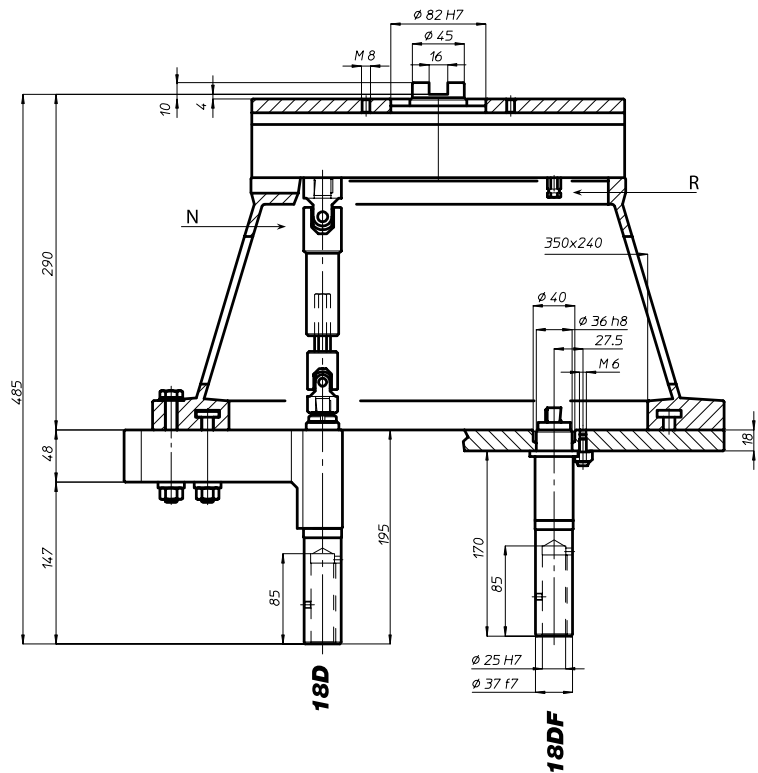

area di lavoro
working area

