

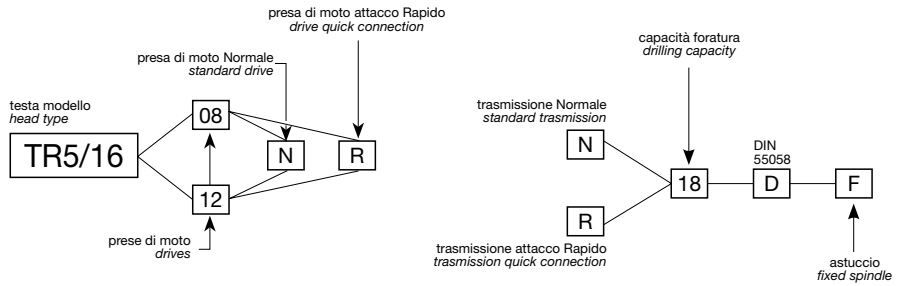

TR5/16





Codice testa
Head code

Codice mandrino
Spindle code





 N° prese di moto
Nr. spindle drives 08-12

 Rapporto
Ratio 1-1

 Capacità di foratura
Drilling capacity
acciaio R=500 N/mm² 16
ghisa: GG25 18

 Maschiatura
Tapping M14

 Attacco utensile
Type of spindle
D DIN 55058 Ø25

 Peso gruppo testa
Head weight Kg 36

 Peso gruppo mandrino
Spindle-set weight Kg 3,3

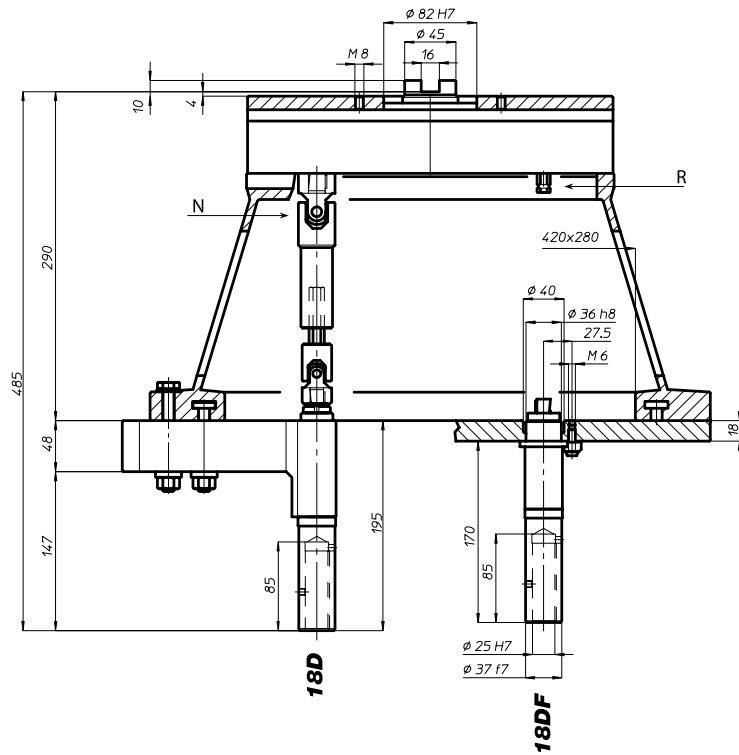

area di lavoro
working area

