

TR8/22

Codice testa
Head code

Codice mandrino
Spindle code

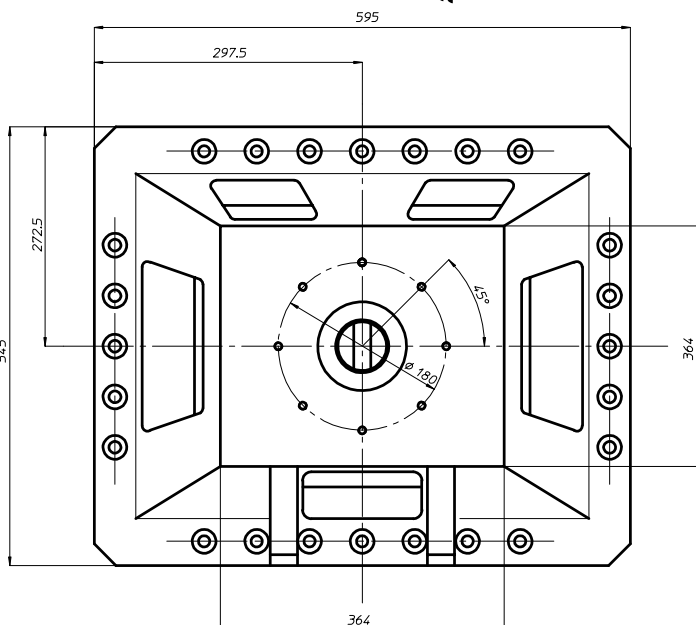
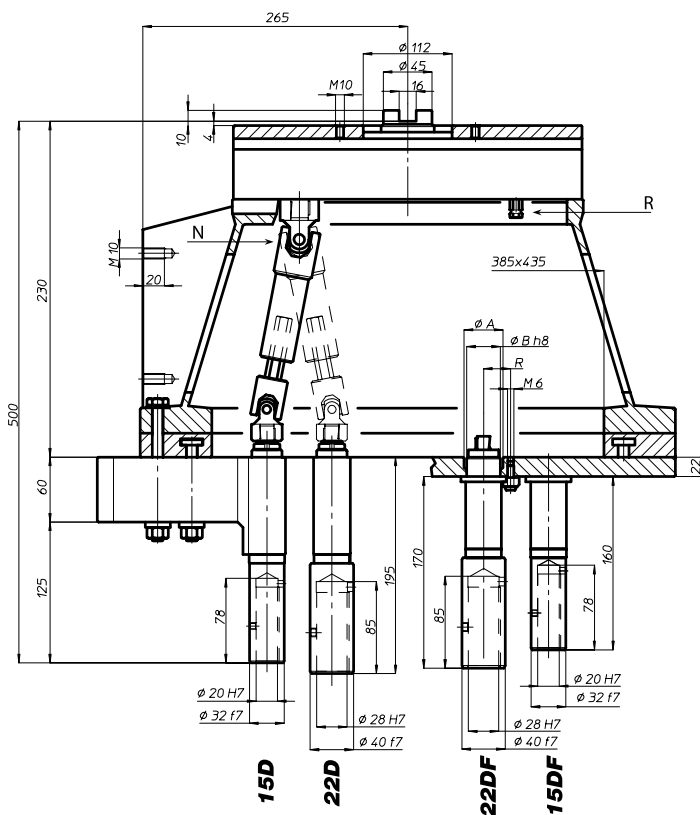
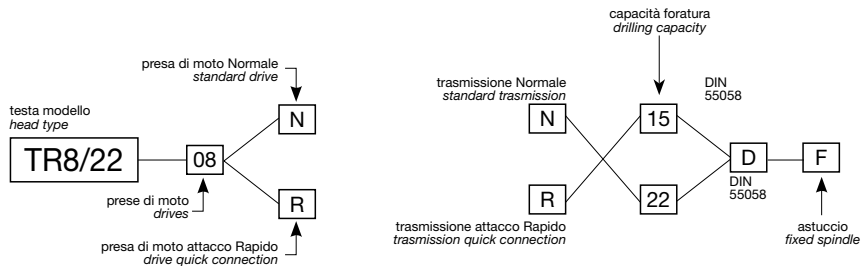

	N° prese di moto Nr. spindle drives	12
	Rapporto Ratio	1-1,5
	Capacità di foratura Drilling capacity acciaio R=500 N/mm ² ghisa: GG25	15D: 13 22D: 20 15D: 15 22D: 22
	Maschiatura Tapping	15D: M12 22D: M16
	Attacco utensile Type of spindle D	DIN 55058 $\phi 20$ - $\phi 28$
	Peso gruppo testa Head weight	Kg 86
	Peso gruppo mandrino Spindle-set weight	15D: Kg 4 22D: Kg 5,5

area di lavoro
working area

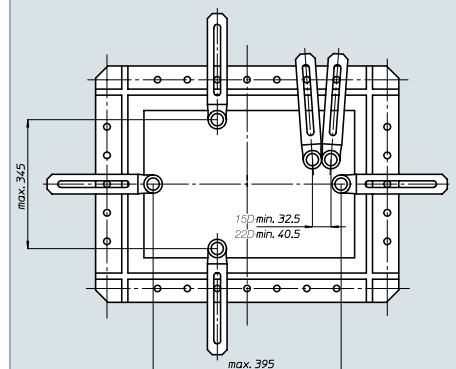

FH

BAH

TA.CP

TA

MO

HT

VH

TSI/TSX

T

MT-TC-TC3

Accessori
Accessories

Appendice tecnica
Technical supplement