

T4

Codice testa
Head code

Codice mandrino
Spindle code

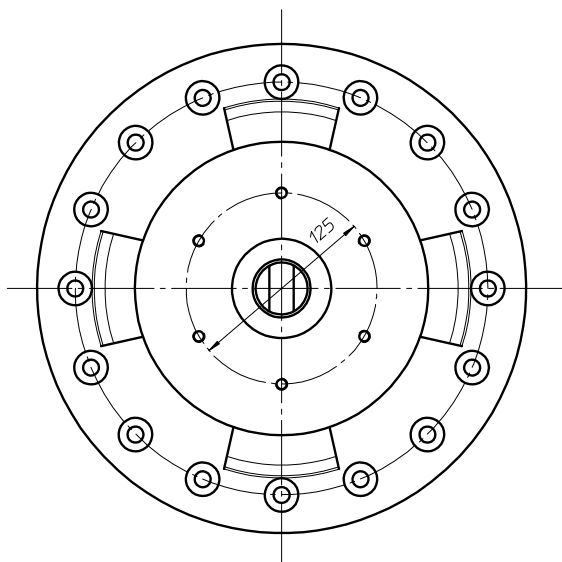
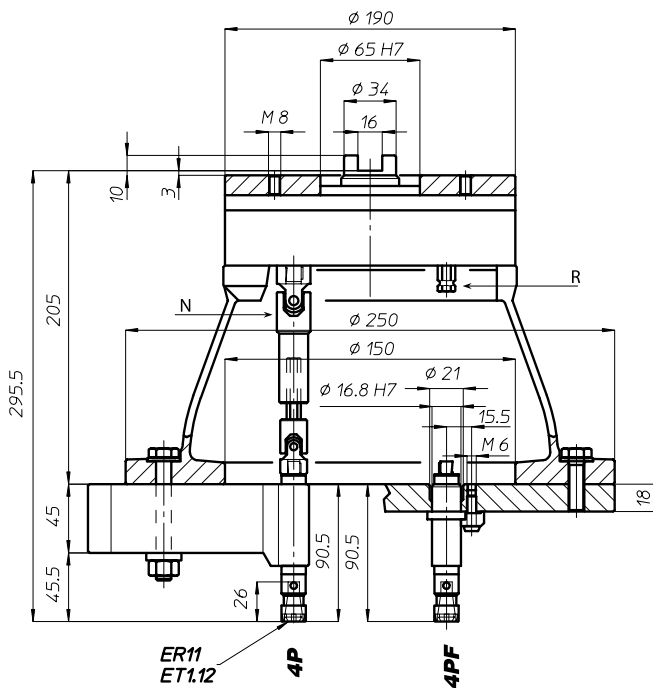
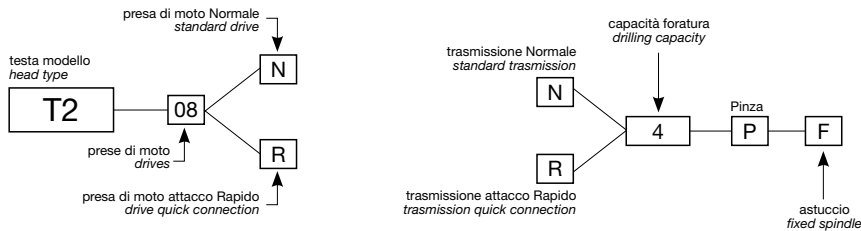

	N° prese di moto Nr. spindle drives	08-12
	Rapporto Ratio	1-1
	Capacità di foratura Drilling capacity acciaio R=500 N/mm ² ghisa: GG25	4 5
	Maschiatura Tapping	M4
	Attacco utensile Type of spindle P	ER11
	Peso gruppo testa Head weight	Kg 9,5
	Peso gruppo mandrino Spindle-set weight	Kg 1

area di lavoro
working area

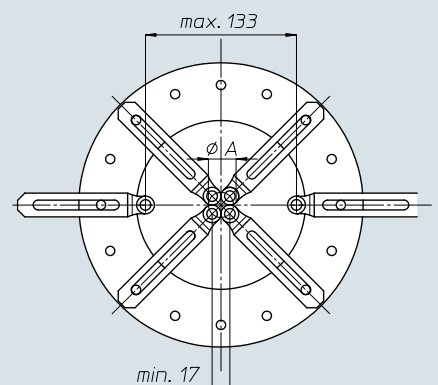

ϕA	n° mandrini n° spindles
20	3
24,5	4
29,5	5
34,5	6
39,5	7
45	8



FH

BAH

TA.CP

TA

MO

HT

VH

TSI/TSX

T

MT-TC-TC3

Accessori
Accessories

Appendice tecnica
Technical supplement

9-3