

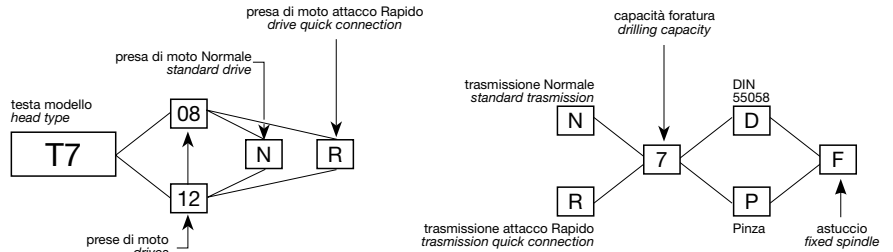

T7

Codice testa
Head code

Codice mandrino
Spindle code



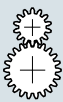

 N° prese di moto
Nr. spindle drives 08-12

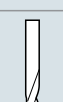
 Rapporto
Ratio 1-1

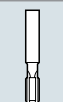
 Capacità di foratura
Drilling capacity
acciaio R=500 N/mm²
ghisa: GG25 6
7

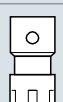
 Maschiatura
Tapping M5

 Attacco utensile
Type of spindle
D P DIN 55058 Ø10
ER11

 Peso gruppo testa
Head weight Kg 10

 Peso gruppo mandrino
Spindle-set weight Kg 1,1

area di lavoro working area

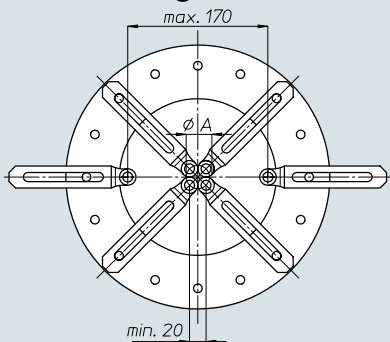

ø A	n° mandrini n° spindles
23,5	3
28,5	4
34,5	5
40,5	6
46,5	7
52,5	8
59	9
65,5	10
71,5	11
77,5	12

