

T10

Codice testa
Head code

Codice mandrino
Spindle code

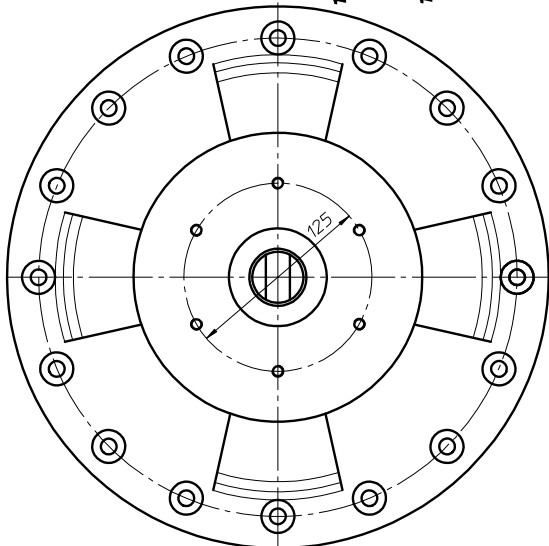
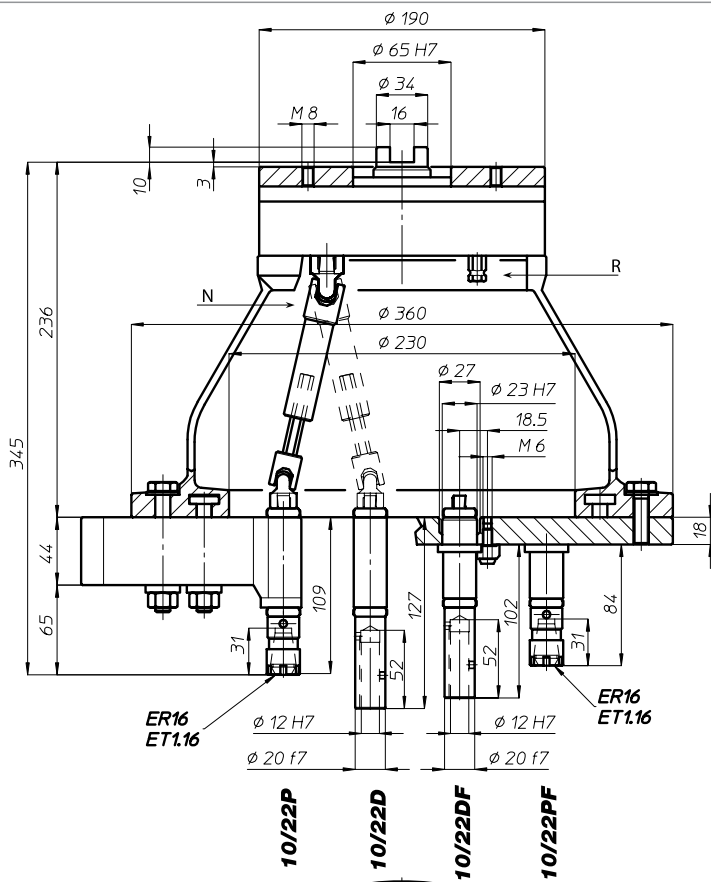
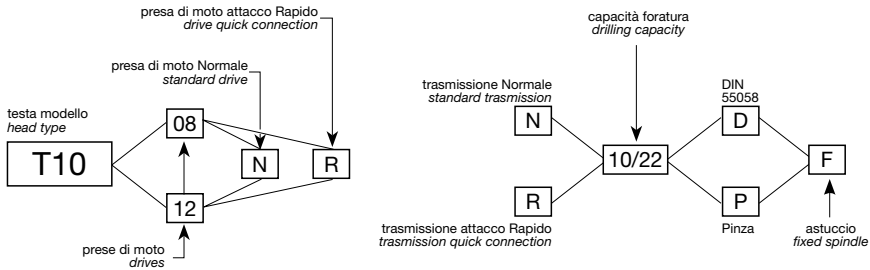

	N° prese di moto Nr. spindle drives	08-12
	Rapporto Ratio	1-1
	Capacità di foratura Drilling capacity acciaio R=500 N/mm ² ghisa: GG25	8 10
	Maschiatura Tapping	M6
	Attacco utensile Type of spindle D P	DIN 55058 Ø12 ER16
	Peso gruppo testa Head weight	Kg 12
	Peso gruppo mandrino Spindle-set weight	Kg 1,5

area di lavoro working area

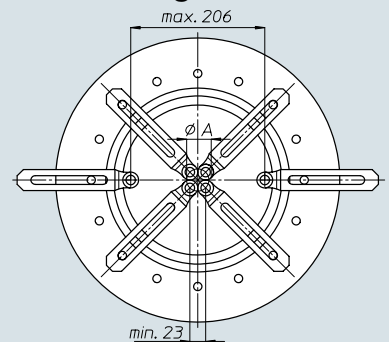

ø A	n° mandrini n° spindles
27	3
33	4
39,5	5
46,5	6
53,5	7
60,5	8
67,5	9
75	10
82	11
89,5	12



FH

BAH

TA-CP

TA

MO

HT

VH

TSI/TSX

T

MT-TC-TC3

Accessori
Accessories

Appendice tecnica
Technical supplement

9-5