

T12-TS12



Codice testa
Head code

Codice mandrino
Spindle code

N° prese di moto
Nr. spindle drives

08-12

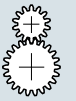

Rapporto
Ratio

1-1



Capacità di foratura
Drilling capacity
acciaio R=500 N/mm²
ghisa: GG25

10
12

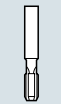

Maschiatura
Tapping

M8



Attacco utensile
Type of spindle
D
P

DIN 55058 Ø16
ER20



Peso gruppo testa
Head weight
T12: Kg 20
TS12: Kg 22,5



Peso gruppo mandrino
Spindle-set weight

Kg 2

area di lavoro
working area

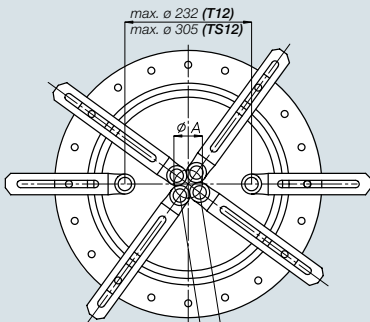

min. 28

n° mandrini
n° spindles

Ø A	n° mandrini n° spindles
33	3
40	4
48	5
56,5	6
65	7
74	8
82,5	9
91	10
100	11
108,5	12

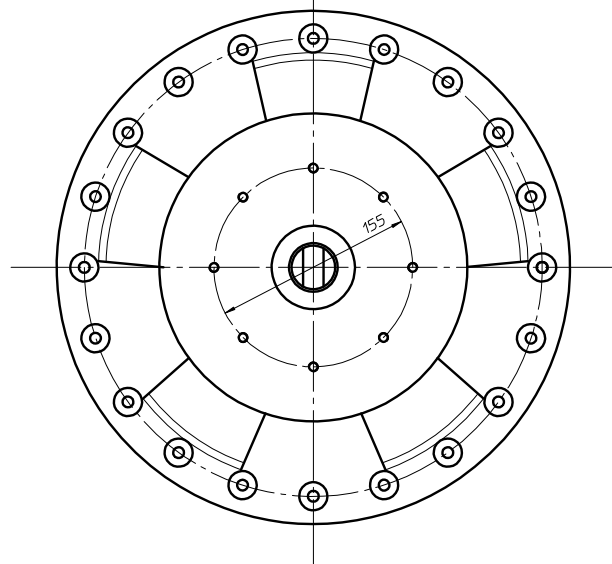
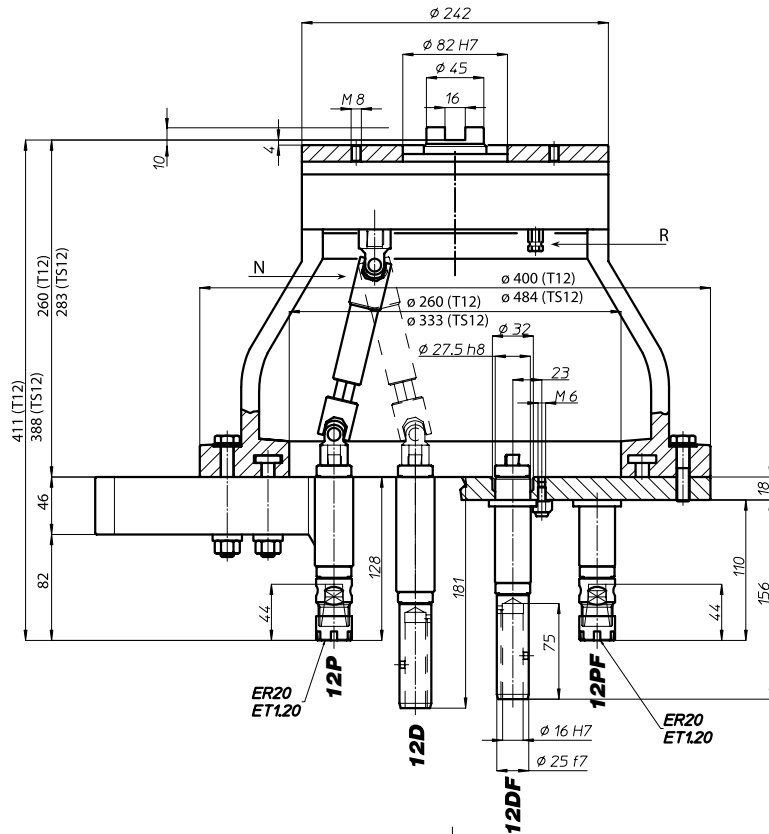
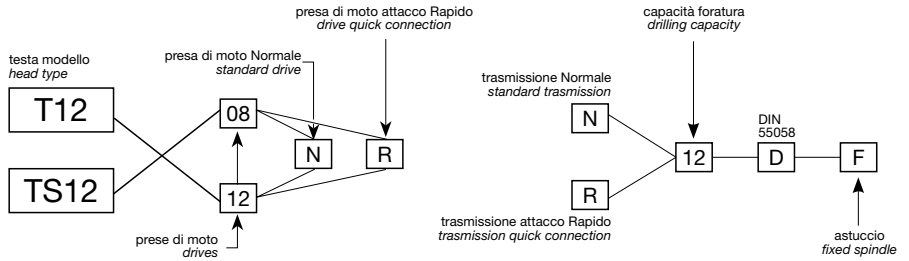

FH

BAH

TA.CP

TA

MO

HT

VH

TSI/TSX

T

MT-TC-TC3

Accessori
Accessories

Appendice tecnica
Technical supplement

9-6

