

T18-TS18

Codice testa
Head code

Codice mandrino
Spindle code



N° prese di moto
Nr. spindle drives

08

Rapporto
Ratio

1-1

Capacità di foratura
Drilling capacity
acciaio R=500 N/mm²
ghisa: GG25

16
18

Maschiatura
Tapping

M14

Attacco utensile
Type of spindle
D

DIN 55058 Ø25

Peso gruppo testa
Head weight

T18: Kg 25
TS18: Kg 26,5

Peso gruppo mandrino
Spindle-set weight

Kg 3,3

area di lavoro
working area

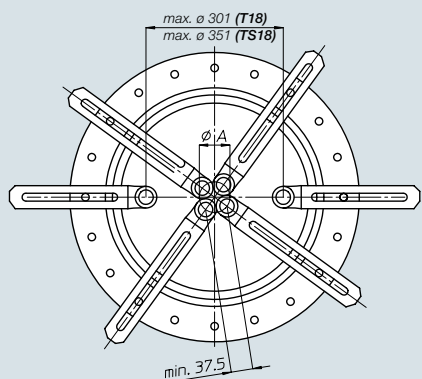

ø A	n° mandrini n° spindles
44	3
53,5	4
64,5	5
75,5	6
87	7
98,5	8

