

 **ZMM**
BULGARIA





- 1-3 ZMM BULGARIA HOLDING
- 4-19 UNIVERSAL LATHES
- 20-35 UNIVERSAL LATHES WITH VARIABLE SPINDLE SPEED CONTROL
- 36-39 OIL COUNTRY LATHES
- 40-49 CNC LATHES
- 50-51 LATHE MACHINE OPTIONAL ACCESSORIES

**WE DO NOT JUST ASSEMBLE.
WE MANUFACTURE.**



ZMM BULGARIA HOLDING



ZMM Bulgaria Holding belongs to the family of **Industrial Holding Bulgaria**. One of the most significant industrial groups in the country, IHB operates mainly in the maritime transport business, ship building and repair, port operations, machine building.

For more information, please visit www.bulgariaholding.com

ZMM Bulgaria Holding is a privately owned company and a leading manufacturer of universal and CNC lathes. The Holding was established in 2001 and currently manages three production facilities, where it employs about 600 professionals.

- **ZMM Sliven:** manufacture of universal lathes, lathes with variable speed control, oil-country lathes, and CNC lathes.
- **IHB Metal Castings:** castings from gray cast iron according to EN 1561/2000; castings from nodular cast iron according EN 1563; patterns.
- **ZMM Nova Zagora:** design and manufacture of assemblies and parts for metal cutting and general machinery products.



ZMM Sliven production plant



ZMM Nova Zagora production plant
tel.:+359 457 630 56
www.zmmnz.com



IHB Metal Castings foundry
tel.:+359 2 836 44 02
www.ihbmetalcastings.com

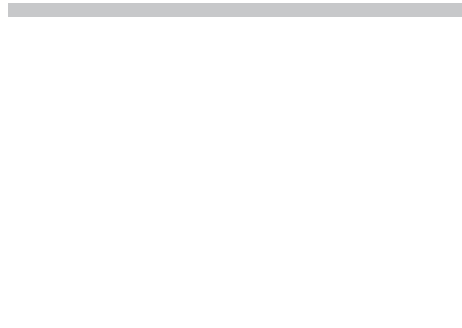

UNIVERSAL LATHES

Our universal lathes and lathes with infinitely variable spindle speed control have diverse features and accessories to meet the needs of clients in various industries and geographical locations. Standard on every machine are metric, inch, module and diametrical pitch threads. Distance between centers varies between 500mm and 10,000mm and center height between 165mm and 705mm. Our lathes are affordable, rugged, reliable and easy to operate. They are built to last and are known for consistent performance and durability even under the most demanding work conditions.

OIL COUNTRY LATHES

Our oil country lathes are designed for turning pipes and pipe fittings for the oil and gas industry. These machines can be used for a variety of turning operations, including cutting metric, inch, module and pitch threads. A standard machine includes two four jaw independent chucks, a taper turning attachment, two stands - one with fixed steady and one with rolling quills. Our spindles are assembled with preloaded angular contact bearings from leading manufacturers like 'SKF' and 'FAG'. All major components are manufactured from stainless steel, which ensures reliable operation and accuracy.

CNC LATHES AND CYCLIC CNC LATHES

Our CNC lathes are available with control systems and servo drives from Siemens, Heidenhain, Fanuc, and Fagor. CNC lathes have a maximum turning diameter over bed of 500, 890, 1090, and 1320mm. They are designed to perform a wide range of turning operations on medium, large and oversized parts in small and medium series production.

Cyclic CNC lathes, although at significantly lower prices than the CNC models, are equally functional and reliable. Longer life expectancy and ease of operation are among their major advantages.

ZMM Bulgaria is among the world's most experienced manufacturers of universal, oil country and CNC lathes and their modifications with infinitely variable spindle speed control. We are well acquainted with customers' needs and are able to render all necessary information, training and technical support at any time – directly or through our distributors. Our service engineers are available and ready to help you out. All you have to do is ask for our machine tool service representative.

All of our equipment comes fully assembled, clearly labeled and includes product manuals with detailed instructions. Our goal is to make installation as easy as possible so you can start producing. If you still have questions after receiving your machine, contact us. We are ready to help.

Fast access to spare parts can help you keep your machines running, control costs, extend the life of your equipment and maintain production levels.



CU325



For illustration purpose only

UNIVERSAL LATHES

STANDART MACHINE SPECIFICATIONS		Unit	CU325
CAPACITY	Height of centers	mm	165
	Swing over bed	mm	325
	Swing over cross slide	mm	190
	Swing in gap – only DBC 1000mm	mm	440
	Width of bed	mm	200
	Distance between centers	mm	500; 750; 1000
SPINDLE	Spindle nose DIN 55027	No	5
	Spindle bore	mm	32
	Spindle taper	Morse	No. 4,5
HEAD STOCK	Number of spindle speeds		12 (24)
	Spindle speed ranges	rpm	85 – 2000 (42,5 – 2000) *
	Main motor power	kw	2,2
FEEDS	Number of feeds		48
	Longitudinal feed range	mm/rev	0,006 – 1,77
	Cross feed range	mm/rev	0,003 – 0,885
THREADS	Number of threads		As below
	Metric thread range	mm	(48) 0,1 – 28
	Inch thread range	Tpi	(53) 75 – 2,5
	Module thread range	Module	(19) 0,1 – 1,75
	DP thread range	DP	(19) 70 – 4
CARRIAGE	Cross slide travel	mm	150
	Top slide travel	mm	95
TAIL STOCK	Quill diameter	mm	40
	Quill taper	Morse	No.3
	Quill travel	mm	100
WEIGHT	For DBC 1000 mm	kg	770

* Only for two-speed motor execution

C400TM

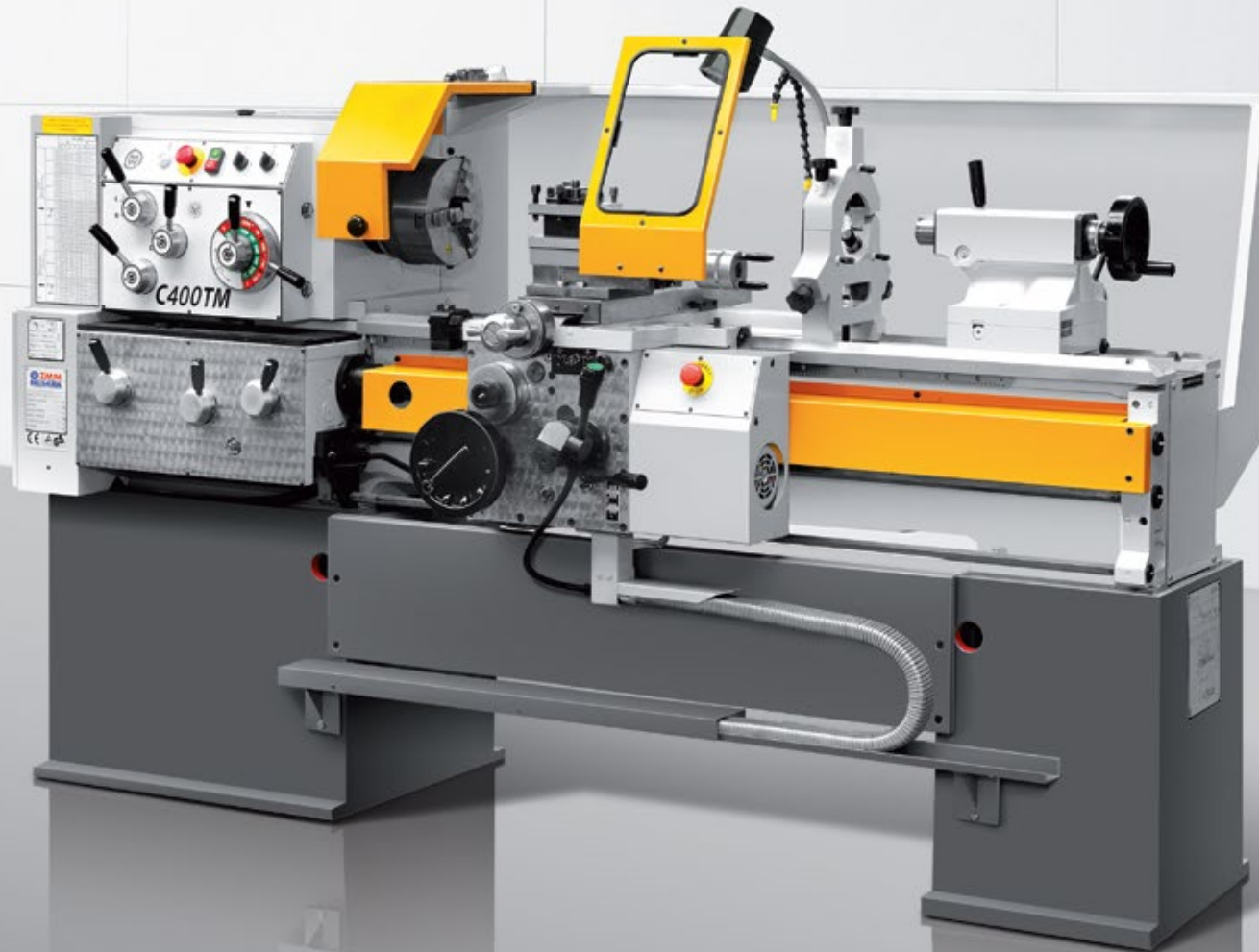

For illustration purpose only

UNIVERSAL LATHES

STANDART MACHINE SPECIFICATIONS		Unit	C400TM
CAPACITY	Height of centers	mm	200
	Swing over bed	mm	400
	Swing over cross slide	mm	235
	Swing in gap	mm	550
	Width of bed	mm	320
	Distance between centers	mm	750; 1000; 1500
	SPINDLE	Spindle nose DIN 55027	No
Spindle bore		mm	52
Spindle taper		Morse	6
HEAD STOCK	Number of spindle speeds		12
	Spindle speed ranges	rpm	50 – 2240
	Main motor power	kw	4
FEEDS	Number of feeds		80
	Longitudinal feed range	mm/rev	0,015 – 0,6
	Cross feed range	mm/rev	0,0075 – 0,3
THREADS	Number of threads		40 of each kind
	Metric thread range	mm	0,25 – 7,5
	Inch thread range	Tpi	120 – 4
	Module thread range	Module	0,0625 – 1,875
	DP thread range	DP	480 – 16
CARRIAGE	Cross slide travel	mm	235
	Top slide travel	mm	110
TAIL STOCK	Quill diameter	mm	60
	Quill taper	Morse	No.4
	Quill travel	mm	100
WEIGHT	For DBC 1500 mm	kg	1700

CU400/CU500

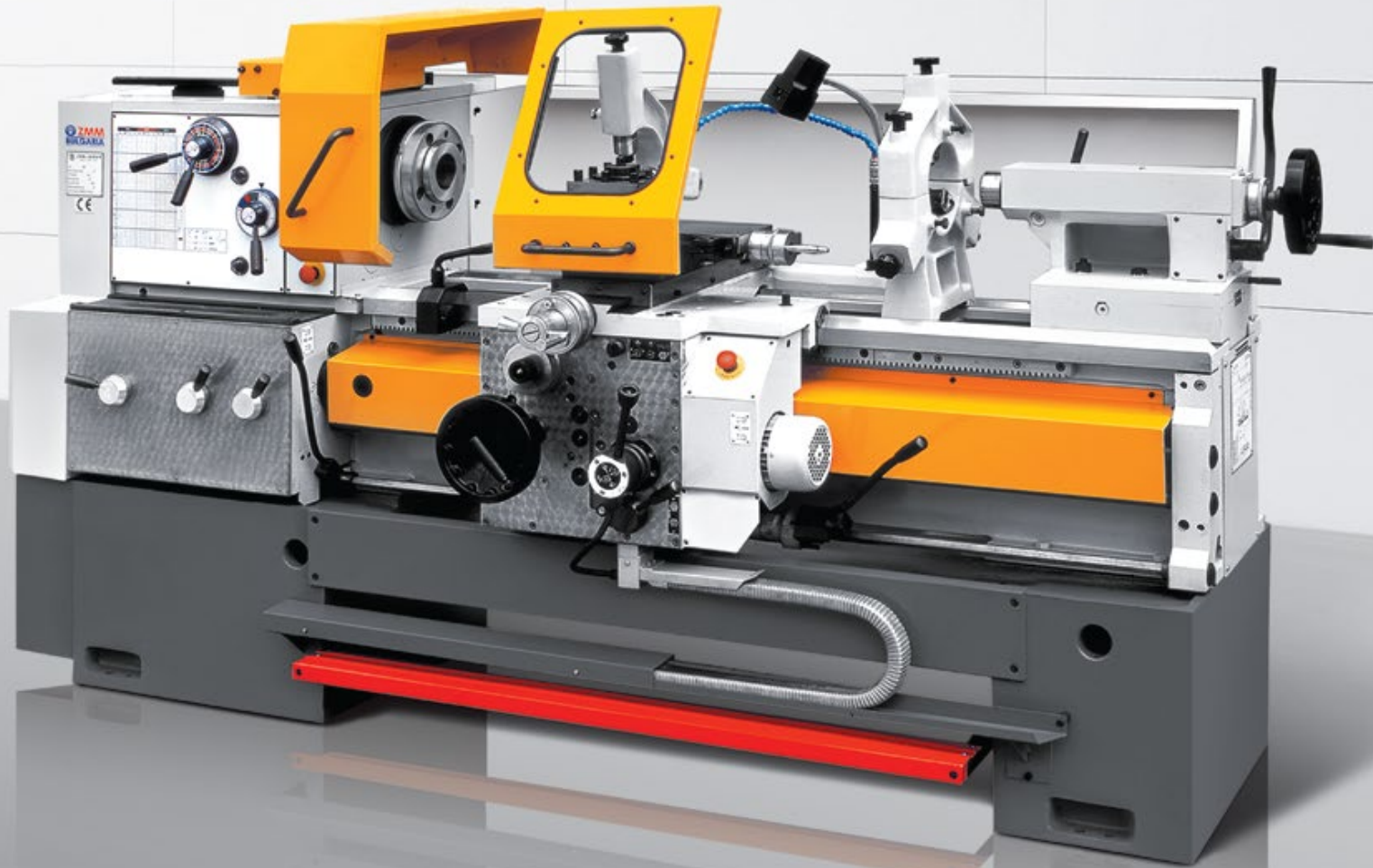

For illustration purpose only

UNIVERSAL LATHES

STANDART MACHINE SPECIFICATIONS		Unit	CU400	CU500
CAPACITY	Height of centers	mm	210	245
	Swing over bed	mm	440	500
	Swing over cross slide	mm	230	300
	Swing in gap	mm	620	670
	Width of bed	mm	360	
	Distance between centers	mm	1000; 1500; 2000	
SPINDLE	Spindle nose DIN 55027	No	8	
	Spindle bore	mm	62	
	Spindle taper	Metric	80	
HEAD STOCK	Number of spindle speeds		21	
	Spindle speed ranges	rpm	20 – 2000	
	Main motor power	kw	7,5	
FEEDS	Number of feeds		120	
	Longitudinal feed range	mm/rev	0,04 – 12	
	Cross feed range	mm/rev	0,02 – 6	
THREADS	Number of threads		64 of each kind	
	Metric thread range	mm	0,5 – 120	
	Inch thread range	Tpi	60 – ¼	
	Module thread range	Module	0,125 – 30	
	DP thread range	DP	240 – 1	
CARRIAGE	Cross slide travel	mm	250	
	Top slide travel	mm	130	
TAIL STOCK	Quill diameter	mm	70	
	Quill taper	Morse	No.5	
	Quill travel	mm	180	
WEIGHT	For DBC 2000 mm	kg	2560	2630

CU400M/ CU500M/ CU580M

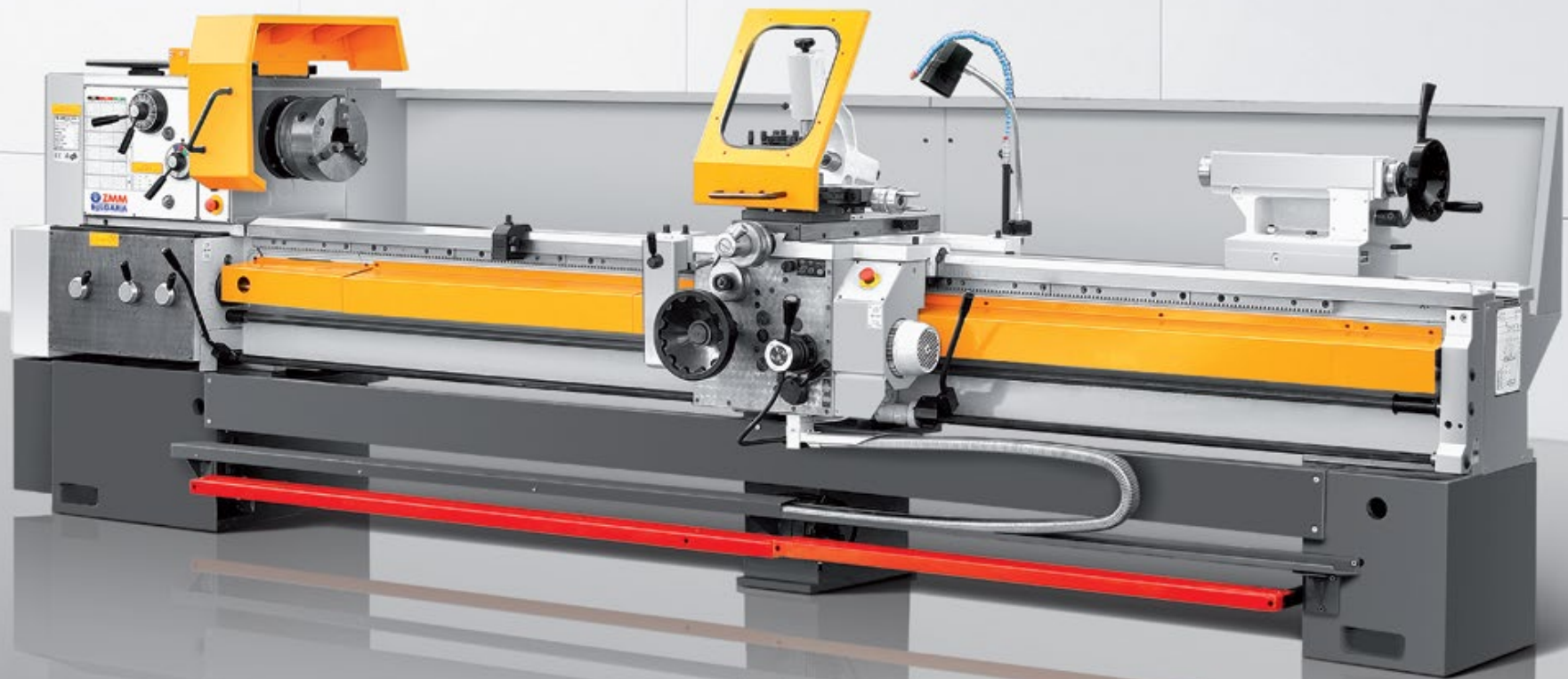

For illustration purpose only



UNIVERSAL LATHES

STANDART MACHINE SPECIFICATIONS		Unit	CU400M	CU500M	CU580M
CAPACITY	Height of centers	mm	220	250	290
	Swing over bed	mm	440	500	580
	Swing over cross slide	mm	240	300	380
	Swing in gap	mm	640	700	780
	Width of bed	mm	400		
	Distance between centers	mm	1000; 1500; 2000; 3000; 4000; 5000		
SPINDLE	Spindle nose DIN 55027	No	8		
	Spindle bore	mm	72		
	Spindle taper	Metric	80		
HEAD STOCK	Number of spindle speeds		21		
	Spindle speed ranges	rpm	20 – 2000		
	Main motor power	kw	7,5 (11)		
FEEDS	Number of feeds		120		
	Longitudinal feed range	mm/rev	0,04 – 12		
	Cross feed range	mm/rev	0,02 – 6		
THREADS	Number of threads		64 of each kind		
	Metric thread range	mm	0,5 – 120		
	Inch thread range	Tpi	60 – ¼		
	Module thread range	Module	0,125 – 30		
	DP thread range	DP	240 – 1		
CARRIAGE	Cross slide travel	mm	315		
	Top slide travel	mm	130		
TAIL STOCK	Quill diameter	mm	90		
	Quill taper	Morse	No.5		
	Quill travel	mm	230		
WEIGHT	For DBC 2000 mm	kg	2900	2950	3010

C11MT

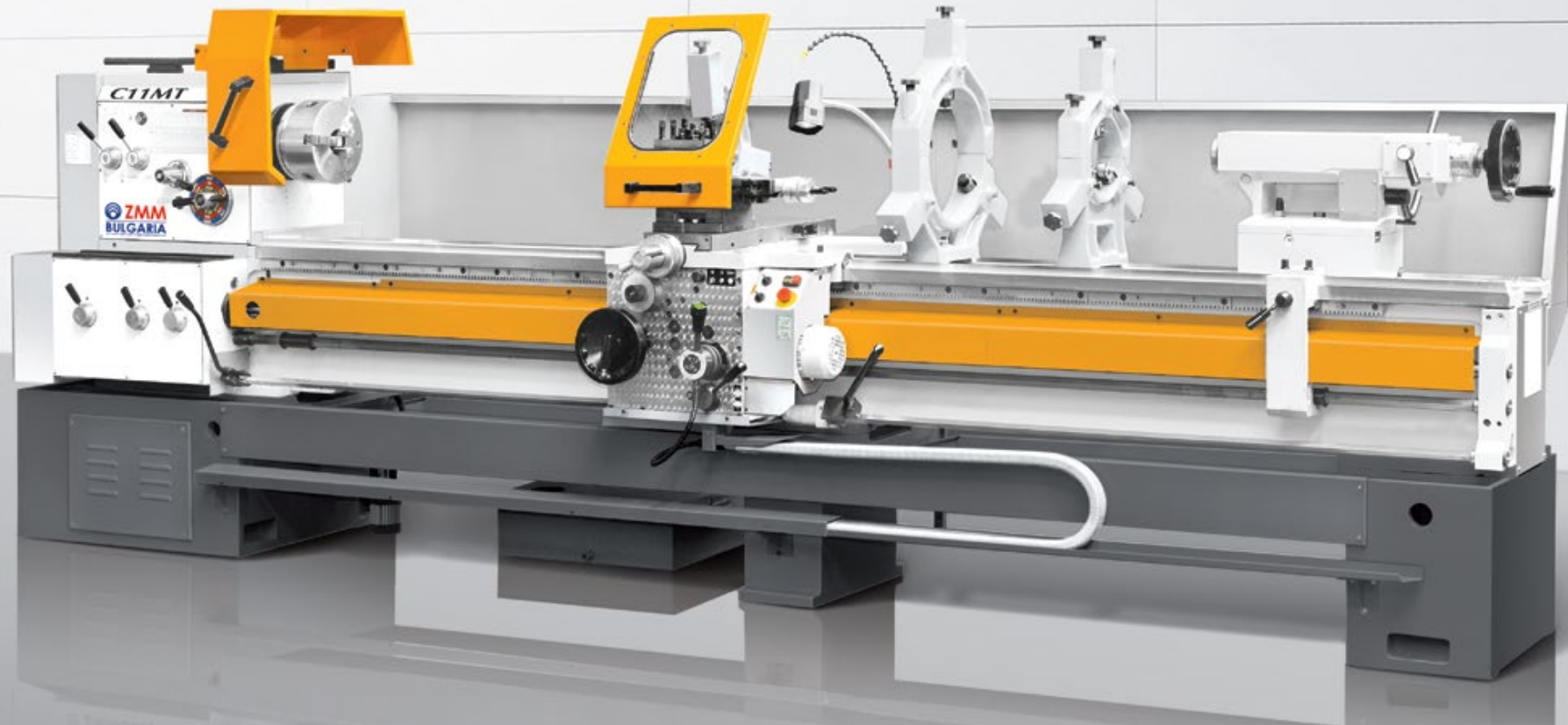

For illustration purpose only



UNIVERSAL LATHES

STANDART MACHINE SPECIFICATIONS

		Unit	C11MT
CAPACITY	Height of centers	mm	300
	Swing over bed	mm	600
	Swing over cross slide	mm	400
	Swing in gap	mm	800
	Width of bed	mm	400
	Distance between centers	mm	1000; 1500; 2000; 3000; 4000; 5000
	SPINDLE	Spindle nose DIN 55027	No
Spindle bore		mm	80
Spindle taper		Metric	90
HEAD STOCK	Number of spindle speeds		16
	Spindle speed ranges	rpm	11,5 – 2000
	Main motor power	kw	7,5
FEEDS	Number of feeds		160
	Longitudinal feed range	mm/rev	0,02 – 12
	Cross feed range	mm/rev	0,01 – 6
THREADS	Number of threads		80 of each kind
	Metric thread range	mm	0,25 – 120
	Inch thread range	Tpi	120 – ¼
	Module thread range	Module	0,0625 – 30
	DP thread range	DP	480 – 1
CARRIAGE	Cross slide travel	mm	315
	Top slide travel	mm	130
TAIL STOCK	Quill diameter	mm	90
	Quill taper	Morse	No.5
	Quill travel	mm	230
WEIGHT	For DBC 2000 mm	kg	3100

CU500MT/ CU630/ CU730

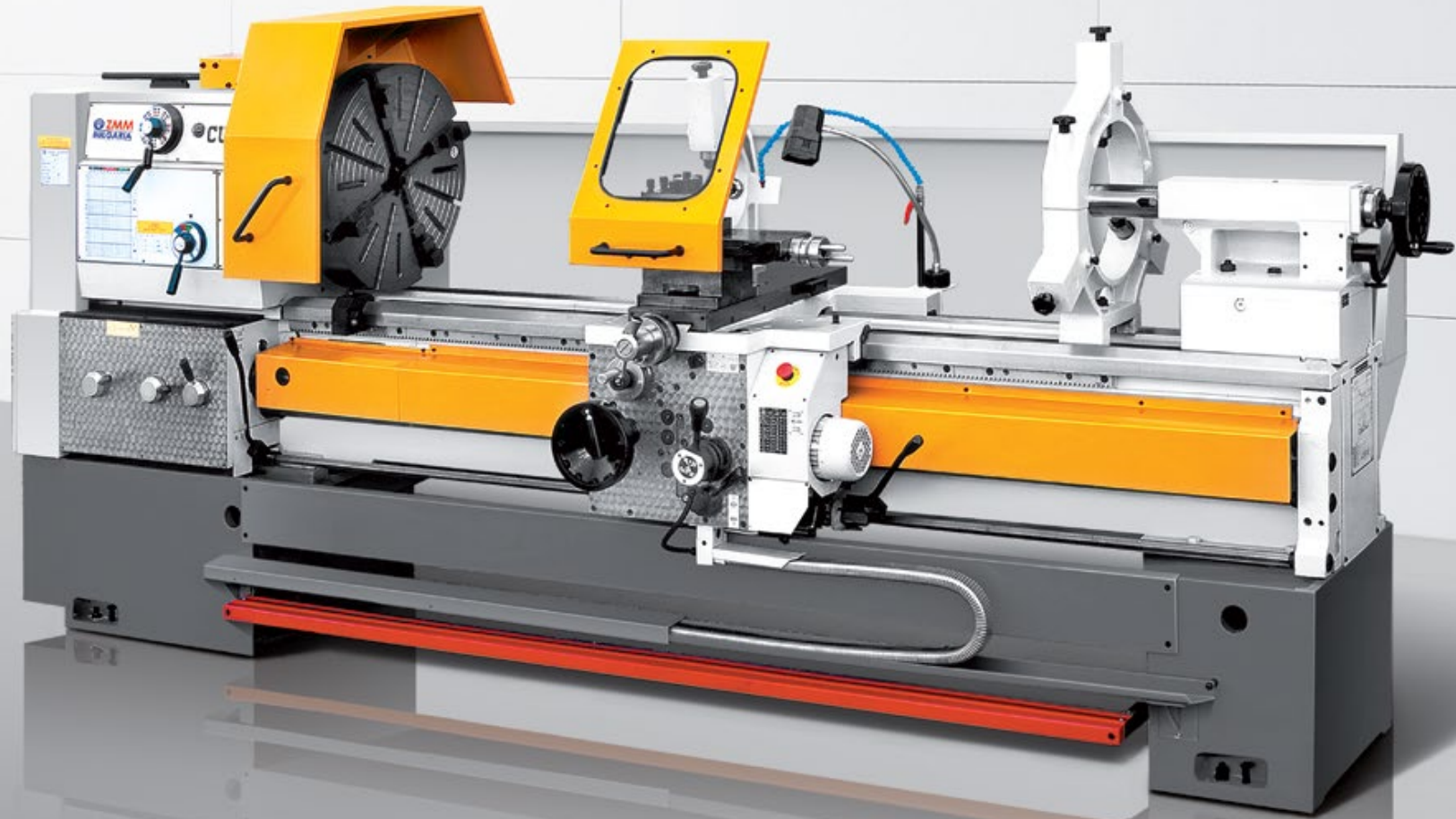

For illustration purpose only



UNIVERSAL LATHES

STANDART MACHINE SPECIFICATIONS		Unit	CU500MT	CU630	CU730
CAPACITY	Height of centers	mm	250	315	365
	Swing over bed	mm	500	630	730
	Swing over cross slide	mm	300	430	500
	Swing in gap	mm	700	830	930
	Width of bed	mm	400		
	Distance between centers	mm	1000; 1500; 2000; 3000; 4000; 5000		
SPINDLE	Spindle nose DIN 55027	No	11		
	Spindle bore	mm	103		
	Spindle taper	Metric	120		
HEAD STOCK	Number of spindle speeds		15	21	
	Spindle speed ranges	rpm	11,5-1400	12,5 - 1250	
	Main motor power	kw	7,5	11	
FEEDS	Number of feeds		120		
	Longitudinal feed range	mm/rev	0,04 – 12		
	Cross feed range	mm/rev	0,02 – 6		
THREADS	Number of threads		64 of each kind		
	Metric thread range	mm	0,5 – 120		
	Inch thread range	Tpi	60 – ¼		
	Module thread range	Module	0,125 – 30		
	DP thread range	DP	240 – 1		
CARRIAGE	Cross slide travel	mm	315	390	
	Top slide travel	mm	130		
TAIL STOCK	Quill diameter	mm	90		
	Quill taper	Morse	No.5		
	Quill travel	mm	230		
WEIGHT	For DBC 2000 mm	kg	3250	3310	3500

C10T/ C10TM/ C10TH

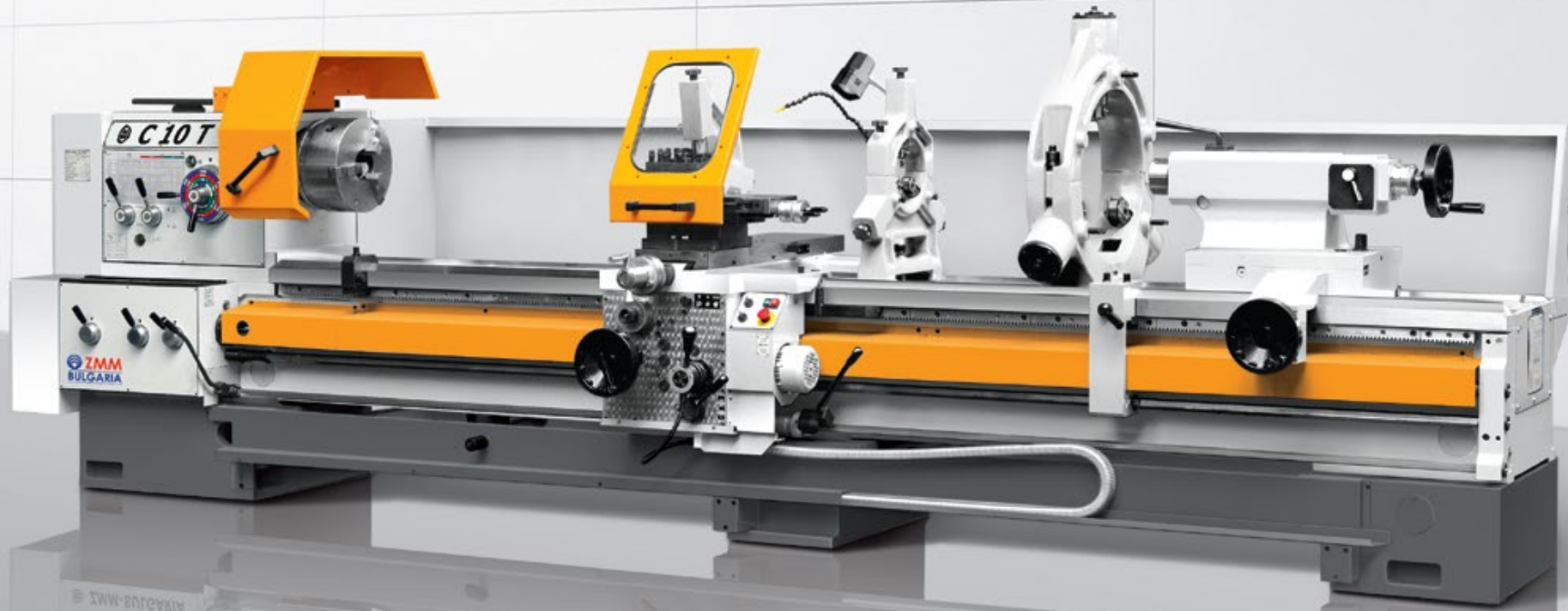

For illustration purpose only



UNIVERSAL LATHES

STANDART MACHINE SPECIFICATIONS		Unit	C10T	C10TM	C10TH
CAPACITY	Height of centers	mm	330	380	430
	Swing over bed	mm	660	760	860
	Swing over cross slide	mm	420	520	620
	Swing in gap	mm	850	950	1050
	Width of bed	mm	560		
	Distance between centers	mm	1500; 2000; 3000; 4000; 5000; 6000		
	SPINDLE	Spindle nose DIN 55027	No	11	
Spindle bore		mm	103	132	
Spindle taper		Metric	120	140	
HEAD STOCK	Number of spindle speeds		15	17	
	Spindle speed ranges	rpm	9-1320	7,5 – 1015	
	Main motor power	kw	11	15	
FEEDS	Number of feeds		150		
	Longitudinal feed range	mm/rev	0,039 – 18		
	Cross feed range	mm/rev	0,02 – 9		
THREADS	Number of threads		76 of each kind		
	Metric thread range	mm	0,5 – 180		
	Inch thread range	Tpi	60 – 1/6		
	Module thread range	Module	0,125 – 45		
	DP thread range	DP	240 – 2/3		
CARRIAGE	Cross slide travel	mm	410	435	
	Top slide travel	mm	150		
TAIL STOCK	Quill diameter	mm	105		
	Quill taper	Morse	No.6		
	Quill travel	mm	225		
WEIGHT	For DBC 2000 mm	kg	4170	4470	4650

CU800/ CU1000/ CU1250



For illustration purpose only



UNIVERSAL LATHES

STANDART MACHINE SPECIFICATIONS		Unit	CU800	CU1000	CU1250
CAPACITY	Height of centers	mm	400	500	625
	Swing over bed	mm	890	1090	1320
	Swing over cross slide	mm	490	690	940
	Swing in gap	mm	1050	1250	1500
	Width of bed	mm	700		
	Distance between centers	mm	1500; 3000; 4000; 5000; 6000		
SPINDLE	Spindle nose DIN 55027	No	15		
	Spindle bore	mm	155		
	Spindle taper	Metric	160		
HEAD STOCK	Number of spindle speeds		24		
	Spindle speed ranges	rpm	6,3 -1250	5 -1000	
	Main motor power	kw	22 (30)		
FEEDS	Number of feeds		160		
	Longitudinal feed range	mm/rev	0,032 – 38,9		
	Cross feed range	mm/rev	0,016 – 19,45		
THREADS	Number of threads		80 of each kind		
	Metric thread range	mm	0,5 – 480		
	Inch thread range	Tpi	60 – 1/16		
	Module thread range	Module	0,125 – 120		
	DP thread range	DP	240 – ¼		
CARRIAGE	Cross slide travel	mm	525		
	Top slide travel	mm	270	670	
TAIL STOCK	Quill diameter	mm	125		
	Quill taper	Morse	No.6		
	Quill travel	mm	260		
WEIGHT	For DBC 3000 mm	kg	7500	8050	8550

CU325RD



For illustration purpose only

UNIVERSAL LATHES WITH VARIABLE SPINDLE SPEED CONTROL

STANDART MACHINE SPECIFICATIONS		Unit	CU325RD
CAPACITY	Height of centers	mm	165
	Swing over bed	mm	325
	Swing over cross slide	mm	190
	Swing in gap – only DBC1000mm	mm	440
	Width of bed	mm	200
	Distance between centers	mm	500; 750; 1000
SPINDLE	Spindle nose DIN 55027	No	5
	Spindle bore	mm	32
	Spindle taper	Morse	No. 4,5
HEAD STOCK	Number of spindle speeds		Infinitely variable in 2 sub-ranges
	Spindle variable speed sub-ranges	rpm	85 - 405; 470 – 2200
	Main motor power	kw	2,2
FEEDS	Number of feeds		48
	Longitudinal feed range	mm/rev	0,006 – 1,77
	Cross feed range	mm/rev	0,003 – 0,885
THREADS	Number of threads		As below
	Metric thread range	mm	(48) 0,1 – 28
	Inch thread range	Tpi	(53) 75 – 2,5
	Module thread range	Module	(19) 0,1 – 1,75
	DP thread range	DP	(19) 70 – 4
CARRIAGE	Cross slide travel	mm	150
	Top slide travel	mm	95
TAIL STOCK	Quill diameter	mm	40
	Quill taper	Morse	No.3
	Quill travel	mm	100
WEIGHT	For DBC 1000 mm	kg	770

C400TS



For illustration purpose only

UNIVERSAL LATHES WITH VARIABLE SPINDLE SPEED CONTROL

STANDART MACHINE SPECIFICATIONS		Unit	C400TS
CAPACITY	Height of centers	mm	200
	Swing over bed	mm	400
	Swing over cross slide	mm	235
	Swing in gap	mm	550
	Width of bed	mm	320
	Distance between centers	mm	750; 1000; 1500
SPINDLE	Spindle nose DIN 55027	No	6
	Spindle bore	mm	52
	Spindle taper	Morse	6
HEAD STOCK	Number of spindle speeds		Infinitely variable in 4 sub-ranges
	Spindle variable speed sub-ranges	rpm	18-98; 48-265; 144-790; 385-2120
	Main motor power	kw	7,5
FEEDS	Number of feeds		80
	Longitudinal feed range	mm/rev	0,015 – 0,6
	Cross feed range	mm/rev	0,0075 – 0,3
THREADS	Number of threads		40 of each kind
	Metric thread range	mm	0,25 – 7,5
	Inch thread range	Tpi	120 – 4
	Module thread range	Module	0,0625 – 1,875
	DP thread range	DP	480 – 16
CARRIAGE	Cross slide travel	mm	235
	Top slide travel	mm	110
TAIL STOCK	Quill diameter	mm	60
	Quill taper	Morse	No.4
	Quill travel	mm	100
WEIGHT	For DBC 1500 mm	kg	1700

CU400MRD/ CU500MRD/ CU580MRD



For illustration purpose only

UNIVERSAL LATHES WITH VARIABLE SPINDLE SPEED CONTROL

STANDART MACHINE SPECIFICATIONS		Unit	CU400MRD	CU500MRD	CU580MRD
CAPACITY	Height of centers	mm	220	250	290
	Swing over bed	mm	440	500	580
	Swing over cross slide	mm	240	300	380
	Swing in gap	mm	640	700	780
	Width of bed	mm	400		
	Distance between centers	mm	1000; 1500; 2000; 3000; 4000; 5000		
SPINDLE	Spindle nose DIN 55027	No	8		
	Spindle bore	mm	72		
	Spindle taper	Metric	80		
HEAD STOCK	Number of spindle speeds		Infinitely variable in 3 sub-ranges		
	Spindle variable speed sub-ranges	rpm	25 - 100; 100 – 400; 500 – 2000		
	Main motor power	kw	11		
FEEDS	Number of feeds		120		
	Longitudinal feed range	mm/rev	0,04 – 12		
	Cross feed range	mm/rev	0,02 – 6		
THREADS	Number of threads		64 of each kind		
	Metric thread range	mm	0,5 – 120		
	Inch thread range	Tpi	60 – ¼		
	Module thread range	Module	0,125 – 30		
	DP thread range	DP	240 – 1		
CARRIAGE	Cross slide travel	mm	315		
	Top slide travel	mm	130		
TAIL STOCK	Quill diameter	mm	90		
	Quill taper	Morse	No.5		
	Quill travel	mm	230		
WEIGHT	For DBC 2000 mm	kg	2900	2950	3010

C11MTS



For illustration purpose only



UNIVERSAL LATHES WITH VARIABLE SPINDLE SPEED CONTROL

STANDART MACHINE SPECIFICATIONS		Unit	C11MTS
CAPACITY	Height of centers	mm	300
	Swing over bed	mm	600
	Swing over cross slide	mm	400
	Swing in gap	mm	800
	Width of bed	mm	400
	Distance between centers	mm	1000; 1500; 2000; 3000; 4000; 5000
	SPINDLE	Spindle nose DIN 55027	No
Spindle bore		mm	80
Spindle taper		Metric	90
HEAD STOCK	Number of spindle speeds		Infinitely variable in 3 sub-ranges
	Spindle variable speed sub-ranges	rpm	8 - 62; 62 - 500; 250 - 2000
	Main motor power	kw	11
FEEDS	Number of feeds		160
	Longitudinal feed range	mm/rev	0,02 – 12
	Cross feed range	mm/rev	0,01 – 6
THREADS	Number of threads		80 of each kind
	Metric thread range	mm	0,25 – 120
	Inch thread range	Tpi	120 – ¼
	Module thread range	Module	0,0625 – 30
	DP thread range	DP	480 – 1
CARRIAGE	Cross slide travel	mm	315
	Top slide travel	mm	130
TAIL STOCK	Quill diameter	mm	90
	Quill taper	Morse	No.5
	Quill travel	mm	230
WEIGHT	For DBC 2000 mm	kg	3100

CU500MTRD/ CU630RD/ CU730RD

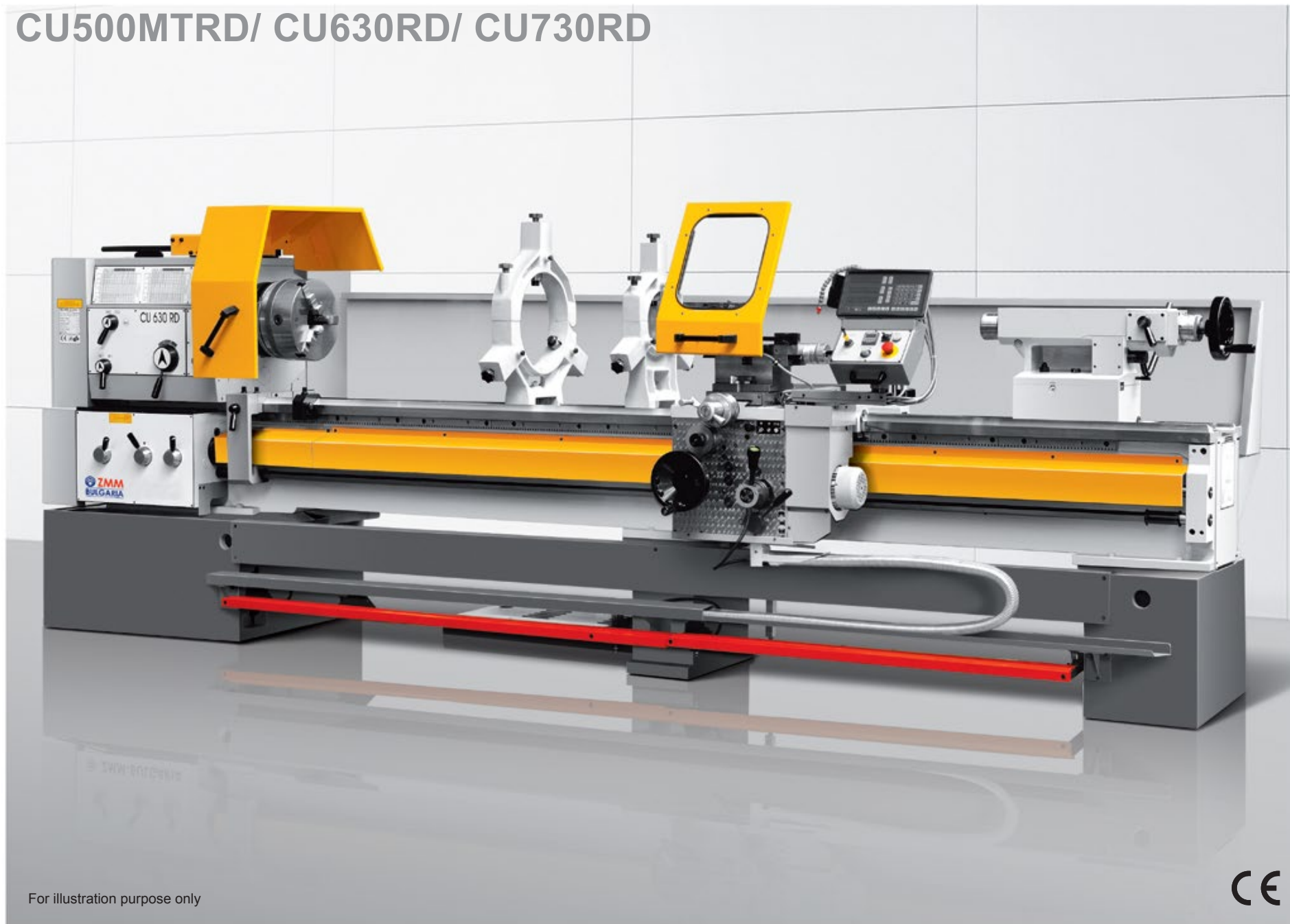

For illustration purpose only



UNIVERSAL LATHES WITH VARIABLE SPINDLE SPEED CONTROL

STANDART MACHINE SPECIFICATIONS		Unit	CU500MTRD	CU630RD	CU730RD
CAPACITY	Height of centers	mm	250	315	365
	Swing over bed	mm	500	630	730
	Swing over cross slide	mm	300	430	500
	Swing in gap	mm	700	830	930
	Width of bed	mm	400		
	Distance between centers	mm	1000; 1500; 2000; 3000; 4000; 5000		
SPINDLE	Spindle nose DIN 55027	No	11		
	Spindle bore	mm	103		
	Spindle taper	Metric	120		
HEAD STOCK	Number of spindle speeds		Infinitely variable in 3 sub-ranges		
	Spindle variable speed sub-ranges	rpm	16-63;63-250;355-1400	16-63; 63-250; 315-1250	
	Main motor power	kw	11		
FEEDS	Number of feeds		120		
	Longitudinal feed range	mm/rev	0,04 – 12		
	Cross feed range	mm/rev	0,02 – 6		
THREADS	Number of threads		64 of each kind		
	Metric thread range	mm	0,5 – 120		
	Inch thread range	Tpi	60 – ¼		
	Module thread range	Module	0,125 – 30		
	DP thread range	DP	240 – 1		
CARRIAGE	Cross slide travel	mm	315	390	
	Top slide travel	mm	130		
TAIL STOCK	Quill diameter	mm	90		
	Quill taper	Morse	No.5		
	Quill travel	mm	230		
WEIGHT	For DBC 2000 mm	kg	3250	3310	3500

C10TS/ C10TMS/ C10THS

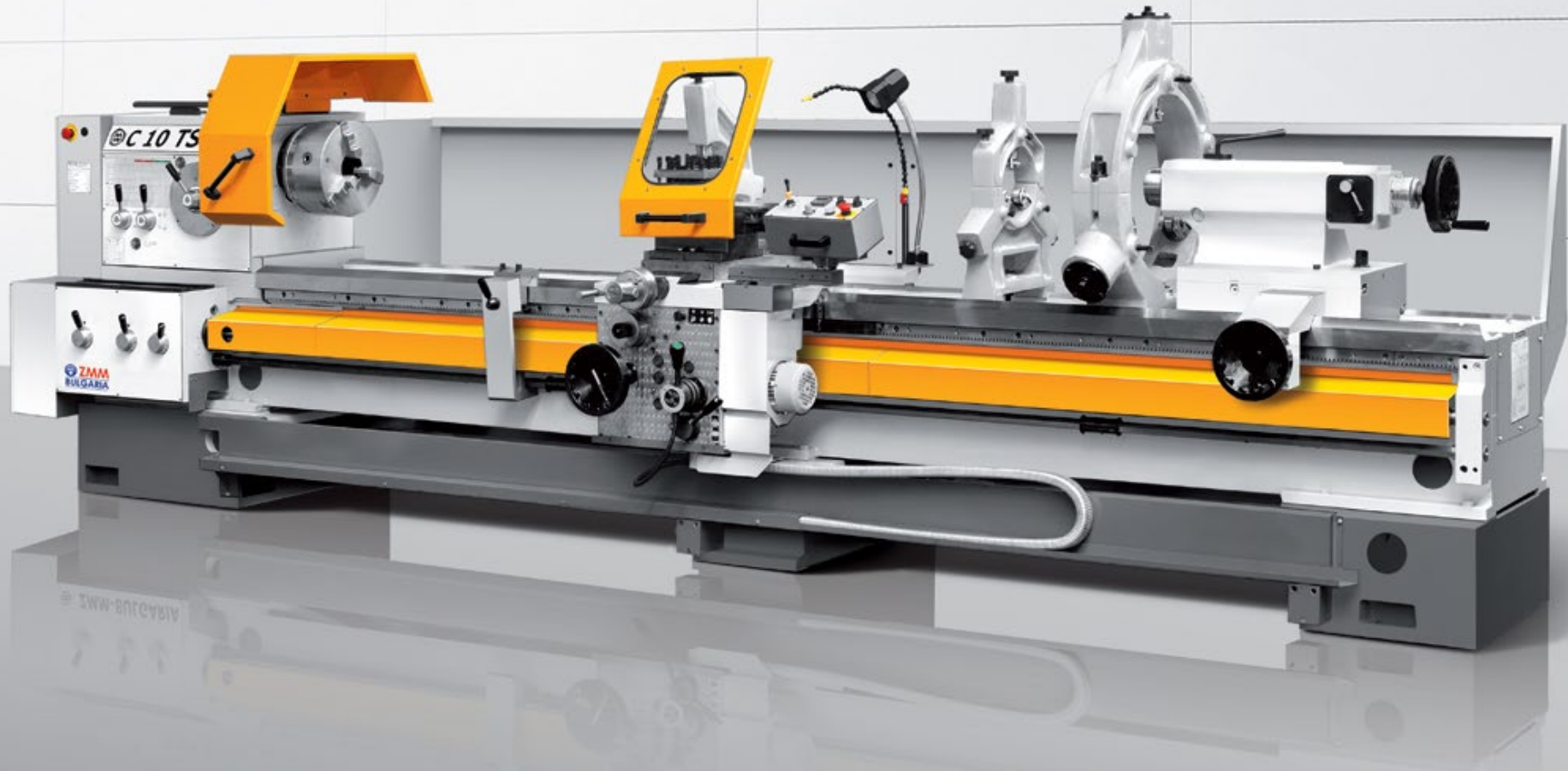

For illustration purpose only



UNIVERSAL LATHES WITH VARIABLE SPINDLE SPEED CONTROL

STANDART MACHINE SPECIFICATIONS		Unit	C10TS	C10TMS	C10THS
CAPACITY	Height of centers	mm	330	380	430
	Swing over bed	mm	660	760	860
	Swing over cross slide	mm	420	520	620
	Swing in gap	mm	850	950	1050
	Width of bed	mm	560		
	Distance between centers	mm	1500; 2000; 3000; 4000; 5000;6000		
SPINDLE	Spindle nose DIN 55027	No	11		
	Spindle bore	mm	103	132	
	Spindle taper	Metric	120	140	
HEAD STOCK	Number of spindle speeds		Infinitely variable in 3 sub-ranges		
	Spindle variable speed sub-ranges	rpm	9-55;37-220;220-1320	7-42;28-170;165-1015	
	Main motor power	kw	15		
FEEDS	Number of feeds		150		
	Longitudinal feed range	mm/rev	0,039 – 18		
	Cross feed range	mm/rev	0,02 – 9		
THREADS	Number of threads		76 of each kind		
	Metric thread range	mm	0,5 – 180		
	Inch thread range	Tpi	60 – 1/6		
	Module thread range	Module	0,125 – 45		
	DP thread range	DP	240 –2/3		
CARRIAGE	Cross slide travel	mm	410	435	
	Top slide travel	mm	150		
TAIL STOCK	Quill diameter	mm	105		
	Quill taper	Morse	No.6		
	Quill travel	mm	225		
WEIGHT	For DBC 2000 mm	kg	4170	4470	4650

CU800RD/ CU1000RD/ CU1250RD



For illustration purpose only

UNIVERSAL LATHES WITH VARIABLE SPINDLE SPEED CONTROL

STANDART MACHINE SPECIFICATIONS		Unit	CU800RD	CU1000RD	CU1250RD
CAPACITY	Height of centers	mm	400	500	625
	Swing over bed	mm	890	1090	1320
	Swing over cross slide	mm	490	690	940
	Swing in gap	mm	1050	1250	1500
	Width of bed	mm	700		
	Distance between centers	mm	1500;3000;4000;5000;6000;7000;8000;9000;10000		
SPINDLE	Spindle nose DIN 55027	No	15		
	Spindle bore	mm	155		
	Spindle taper	Metric	160		
HEAD STOCK	Number of spindle speeds		Infinitely variable in 4 sub-ranges		
	Spindle variable speed sub-ranges	rpm	3,7-15,6; 14,7-62; 58-250; 235-1000		
	Main motor power	kw	30		
FEEDS	Number of feeds		160		
	Longitudinal feed range	mm/rev	0,032 – 38,9		
	Cross feed range	mm/rev	0,016 – 19,45		
THREADS	Number of threads		80 of each kind		
	Metric thread range	mm	0,5 – 480		
	Inch thread range	Tpi	60 – 1/16		
	Module thread range	Module	0,125 – 120		
	DP thread range	DP	240 – ¼		
CARRIAGE	Cross slide travel	mm	525	670	
	Top slide travel	mm	270		
TAIL STOCK	Quill diameter	mm	125		
	Quill taper	Morse	No.6		
	Quill travel	mm	260		
WEIGHT	For DBC 3000 mm	kg	7500	8050	8550

CU1410RD



For illustration purpose only



UNIVERSAL LATHES WITH VARIABLE SPINDLE SPEED CONTROL

STANDART MACHINE SPECIFICATIONS		Unit	CU1410RD
CAPACITY	Height of centers	mm	705
	Swing over bed	mm	1410
	Swing over cross slide	mm	1000
	Width of bed	mm	800
	Distance between centers	mm	2000; 3000; 4000; 5000; 6000; 7000; 8000; 9000
SPINDLE	Spindle nose DIN 55027	No	A 15
	Spindle bore	mm	205
	Spindle taper	Metric	215
HEAD STOCK	Number of spindle speeds		Infinitely variable in 4 sub-ranges
	Spindle variable speed sub-ranges	rpm	1,5-8; 5-31; 20-125; 80-500
	Main motor power	kw	45
FEEDS	Number of feeds		160
	Longitudinal feed range	mm/rev	0,032 – 38,9
	Cross feed range	mm/rev	0,016 – 19,45
THREADS	Number of threads		80 of each kind
	Metric thread range	mm	0,5 – 480
	Inch thread range	Tpi	60 – 1/16
	Module thread range	Module	0,125 – 120
	DP thread range	DP	240 – ¼
CARRIAGE	Cross slide travel	mm	730
	Top slide travel	mm	350
TAIL STOCK	Quill diameter	mm	200
	Quill taper	Morse	No.7
	Quill travel	mm	300
WEIGHT	For DBC 3000 mm	kg	14000

C10T.10/ C10T.12

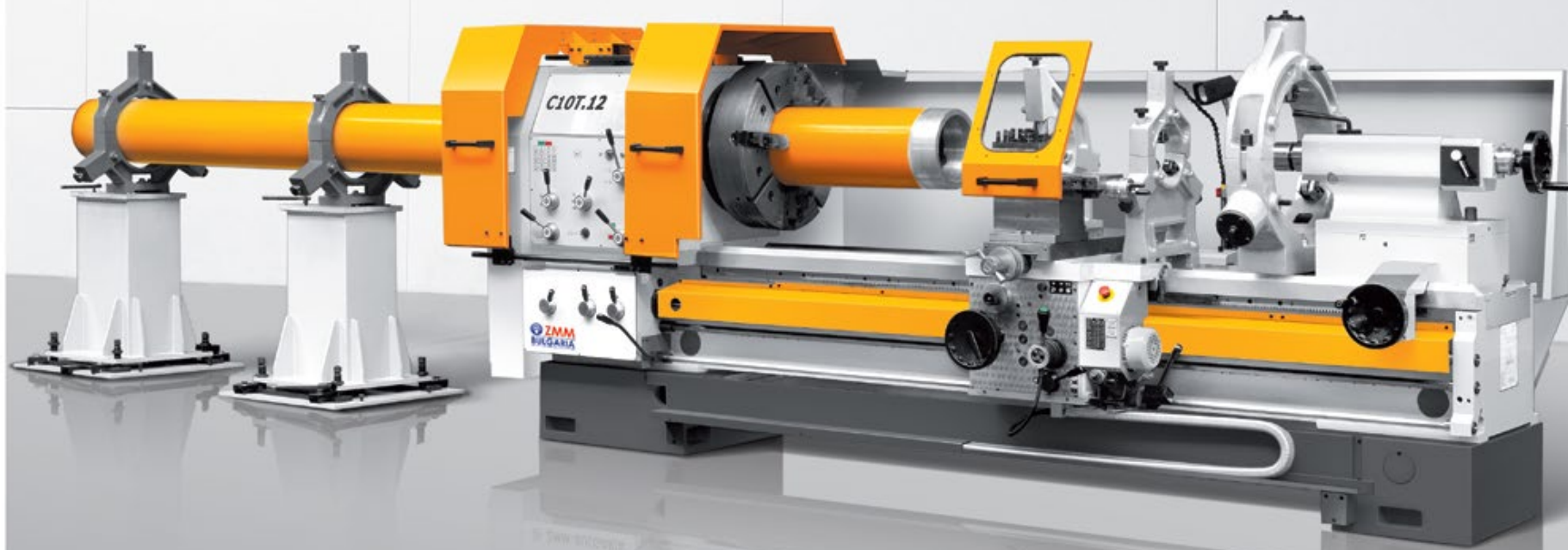

For illustration purpose only



OIL COUNTRY LATHES

STANDART MACHINE SPECIFICATIONS		Unit	C10T.10	C10T.12
CAPACITY	Height of centers	mm	400	
	Swing over bed	mm	800	
	Swing over cross slide	mm	560	
	Swing in gap	mm	990	
	Width of bed	mm	560	
	Distance between centers	mm	1500;2000;3000;4000;5000;6000	
	SPINDLE	Spindle nose DIN 55027 SAS B5.9	No	A20 – A2.20
Spindle bore		mm	260	315
Spindle taper		Metric	318	
HEAD STOCK	Number of spindle speeds		12	
	Spindle variable speed sub-ranges	rpm	8-400 (10-480)	
	Main motor power	kw	11 (15)	
FEEDS	Number of feeds		152	
	Longitudinal feed range	mm/rev	0,039 – 15	
	Cross feed range	mm/rev	0,02 – 7,5	
THREADS	Number of threads		76 of each kind	
	Metric thread range	mm	0,5 – 150	
	Inch thread range	Tpi	60 – 1/5	
	Module thread range	Module	0,125 – 37,5	
	DP thread range	DP	240 – 4/5	
CARRIAGE	Cross slide travel	mm	410	
	Top slide travel	mm	150	
TAIL STOCK	Quill diameter	mm	105	
	Quill taper	Morse	No.6	
	Quill travel	mm	225	
WEIGHT	For DBC 2000 mm	kg	6000	6100

C10T.14



For illustration purpose only



OIL COUNTRY LATHES

STANDART MACHINE SPECIFICATIONS		Unit	C10T.14
CAPACITY	Height of centers	mm	510
	Swing over bed	mm	1020
	Swing over cross slide	mm	780
	Swing in gap	mm	1210
	Width of bed	mm	560
	Distance between centers	mm	1500; 2000; 3000; 4000; 5000; 6000
	SPINDLE	Spindle nose DIN 55027 SAS B5.9	No
Spindle bore		mm	358
Spindle taper		Metric	360
HEAD STOCK	Number of spindle speeds		12
	Spindle variable speed sub-ranges	rpm	6,3 - 315
	Main motor power	kw	18,5
FEEDS	Number of feeds		152
	Longitudinal feed range	mm/rev	0,039 – 15
	Cross feed range	mm/rev	0,02 – 7,5
THREADS	Number of threads		76 of each kind
	Metric thread range	mm	0,5 – 150
	Inch thread range	Tpi	60 – 1/5
	Module thread range	Module	0,125 – 37,5
	DP thread range	DP	240 – 4/5
CARRIAGE	Cross slide travel	mm	510
	Top slide travel	mm	280
TAIL STOCK	Quill diameter	mm	105
	Quill taper	Morse	No.6
	Quill travel	mm	225
WEIGHT	For DBC 2000 mm	kg	7100

LT580



For illustration purpose only

CNC LATHES

STANDART MACHINE SPECIFICATIONS		Unit	LT580	LT580M
CAPACITY	Height of centers	mm	290	
	Swing over bed	mm	580	
	Swing over cross slide	mm	380	310
	Width of bed	mm	400	
	Distance between centers	mm	1000;1500;2000;3000;4000;5000	1000; 1500; 2000
SPINDLE	Spindle nose DIN 55027	No	8	
	Front bearing diameter	mm	120	
	Spindle bore	mm	72	
	Spindle taper	Metric	80	
HEAD STOCK	Number of spindle speed		3	
	I-Range	rpm	25 – 100	25 - 125
	II-Range	rpm	100 - 400	100 - 500
	III-Range	rpm	500 - 2000	500 - 2500
TRAVELS AND FEEDS	Longitudinal feed (Z-axis)	m/min	8 (max)	
	Lateral feed (X-axis)	m/min	8 (max)	
	Rapid traverse (Z and X-axis)	m/min	8 (max)	
	Cross slide maximum travel	mm	290	350
BALL SCREW	Z-axis	mm	50x10	
	X-axis	mm	32x5	40 x 10
TAILSTOCK	Quill Diameter	mm	90	
	Quill Travel	mm	230	
	Quill internal taper	Morse	5	
DRIVES	Main drive power	kW	11kW (AT160M4)	15 kW
	Z-axis servo drive power	kW/N.m	20 N.m (3,1kW)	
	X-axis servo drive power	kW/N.m	11 N.m (1,9kW)	
	Spindle maximum torque	N.m	1120	
	Z-axis tow strength	daN	1450	
	X-axis tow strength	daN	1050	
TOOL HOLDER	Quick change type		MC	BSV N200
CNC SYSTEM			Siemens	
WEIGHT	For DBC 1885 mm	kg	3800	

CNC System and servo drives available also: Heidenhain;Fanuc;Fagor

LT660/ LT760/ LT860



For illustration purpose only



CNC LATHES

STANDART MACHINE SPECIFICATIONS		Unit	LT660	LT760	LT860
CAPACITY	Height of centers	mm	330	380	430
	Swing over bed	mm	660	760	860
	Swing over cross slide	mm	420	520	620
	Width of bed	mm	560		
	Distance between centers	mm	1500; 2000; 3000; 4000; 5000; 6000		
SPINDLE	Spindle nose DIN 55027	No	11		
	Front bearing diameter	mm	140	170	
	Spindle bore	mm	103	132	
	Spindle taper	Metric	120	140	
HEAD STOCK	Number of spindle speed		3		
	I-Range	rpm	9 – 55	7- 42	
	II-Range	rpm	37 - 220	28 - 170	
	III-Range	rpm	220-1320	165 - 1015	
TRAVELS AND FEEDS	Longitudinal feed (Z-axis)	m/min	8 (max)		
	Lateral feed (X-axis)	m/min	8 (max)		
	Rapid traverse (Z and X-axis)	m/min	8 (max)		
	Cross slide maximum travel	mm	430		
BALL SCREW	Z-axis	mm	50x10		
	X-axis	mm	32x5		
TAILSTOCK	Quill Diameter	mm	105		
	Quill Travel	mm	225		
	Quill internal taper	Morse	6		
DRIVES	Main drive power	kW	15Kw	18,5kW	
	Z-axis servo drive power	kW/N.m	18 N.m (3,77kW)		
	X-axis servo drive power	kW/N.m	11 N.m (2,29kW)		
	Spindle maximum torque	N.m	2000	2250	
	Z-axis tow strength	daN	1250		
	X-axis tow strength	daN	1050		
TOOL HODLER	Quick change type		MC		
CNC SYSTEM			Siemens		
WEIGHT	For DBC 3000 mm	kg	5700	6060	6300

CNC System and servo drives also available from: Heidenhain;Fanuc;Fagor

LTC10T.10/ LTC10T.12



For illustration purpose only



CNC LATHES

STANDART MACHINE SPECIFICATIONS		Unit	LTC10T.10	LTC10T.12
CAPACITY	Height of centers	mm	400	
	Swing over bed	mm	800	
	Swing over cross slide	mm	560	
	Width of bed	mm	560	
	Distance between centers	mm	1500;2000;3000;4000;5000;6000	
SPINDLE	Spindle nose DIN 55027	No	A 20 / A2 20	
	Front bearing diameter	mm	380	
	Spindle bore	mm	260	315
	Number of spindle speeds		4	
HEAD STOCK	I - Range	rpm	8 – 40	
	II - Range	rpm	16 – 80	
	III - Range	rpm	40 - 200	
	IV - Range	rpm	80 - 400	
TRAVELS AND FEEDS	Longitudinal feed (Z-axis)	m/min	8 (max)	
	Lateral feed (X-axis)	m/min	8 (max)	
	Rapid traverse (Z and X-axis)	m/min	8 (max)	
	Cross slide maximum travel	mm	390	
BALL SCREW	Z-axis	mm	50x10	
	X-axis	mm	32x5	
TAILSTOCK	Quill diameter	mm	105	
	Quill travel	mm	225	
	Quill taper	Morse	6	
DRIVES	Main drive power	kW	18,5kW	
	Z-axis servo drive power	kW/N.m	18 N.m (3,77kW)	
	X-axis servo drive power	kW/N.m	11 N.m (2,29kW)	
	Spindle maximum torque	N.m	3500	
	Z-axis tow strength	daN	1250	
	X-axis tow strength	daN	1050	
TOOL HOLDER	Quick change type		MC	
CNC SYSTEM			Siemens	
WEIGHT	For DBC 3000 mm	kg	6100	

CNC System and servo drives also available from: Heidenhain;Fanuc;Fagor

LT800/ LT1000/ LT1250



For illustration purpose only

CNC LATHES

STANDART MACHINE SPECIFICATIONS

		Unit	LT800	LT1000	LT1250
CAPACITY	Height of centers	mm	410	510	635
	Swing over bed	mm	890	1090	1320
	Swing over cross slide	mm	490	690	940
	Width of bed	mm	700		
	Distance between centers	mm	1500;3000;4000;5000;6000		
SPINDLE	Spindle nose DIN 55027	No	15		
	Front bearing diameter	mm	200		
	Spindle bore	mm	155		
	Spindle taper	Metric	160		
HEAD STOCK	Number of spindle speeds		4		
	I - Range	rpm	3,7 – 15,6		
	II - Range	rpm	14,7 – 62		
	III - Range	rpm	58 – 250		
	IV - Range	rpm	235 - 1000		
TRAVELS AND FEEDS	Longitudinal feed (Z-axis)	m/min	8 (max)		
	Lateral feed (X-axis)	m/min	8 (max)		
	Rapid traverse (Z and X-axis)	m/min	8 (max)		
	Cross slide maximum travel	mm	525	650	
BALL SCREW	Z-axis	mm	63x10		
	X-axis	mm	40x10		
TAIL STOCK	Quill diameter	mm	125		
	Quill travel	mm	250		
	Quill taper	Morse	6		
DRIVES	Main drive power	kW	30kW		
	Z-axis servo drive power	kW/N.m	30 N.m (5kW)		
	X-axis servo drive power	kW/N.m	15 N.m (2kW)		
	Spindle maximum torque	N.m	5000		
	Z-axis tow strength	daN	1600		
	X-axis tow strength	daN	800		
TOOL HOLDER	Quick change type		MD1		
CNC SYSTEM			Siemens		
WEIGHT	For DBC 3000 mm	kg	8800	9300	9800

CNC System and servo drives also available from: Heidenhain;Fanuc;Fagor

LCC800/ LCC1000/ LCC1250



For illustration purpose only

CNC LATHES

STANDART MACHINE SPECIFICATIONS

		Unit	LCC800	LCC1000	LCC1250
CAPACITY	Height of centers	mm	410	510	635
	Swing over bed	mm	890	1090	1320
	Swing over cross slide	mm	490	690	940
	Width of bed	mm	700		
	Distance between centers	mm	1500; 3000; 4000; 5000; 6000		
SPINDLE	Spindle nose DIN 55027	No	15		
	Front bearing diameter	mm	200		
	Spindle bore	mm	155		
	Spindle taper	Metric	160		
HEAD STOCK	Number of spindle speeds		2		
	I - Range	rpm	2 - 180		
	II - Range	rpm	8 - 700		
TRAVELS AND FEEDS	Longitudinal feed (Z-axis)	m/min	8 (max)		
	Lateral feed (X-axis)	m/min	8 (max)		
	Rapid traverse (Z and X-axis)	m/min	8 (max)		
	Cross slide maximum travel	mm	525	650	
BALL SCREW	Z-axis	mm	63 x 10		
	X-axis	mm	40 x 10		
TAIL STOCK	Quill diameter	mm	125		
	Quill travel	mm	250		
	Quill taper	Morse	6		
DRIVES	Main drive power	kW	30kW		
	Z-axis servo drive power	kW/N.m	30 N.m (5 kW)		
	X-axis servo drive power	kW/N.m	15 N.m (2 kW)		
	Spindle maximum torque	N.m	5000		
	Z-axis tow strength	daN	1600		
	X-axis tow strength	daN	800		
TOOL HOLDER	Quick change type		MD1		
CNC SYSTEM			Siemens		
WEIGHT	For DBC 3000 mm	kg	8800	9300	9800

CNC System and servo drives also available from: Heidenhain;Fanuc;Fagor

LATHE MACHINE OPTIONAL ACCESSORIES

N	OPTIONAL ACCESSORY	SPECIFICATIONS	CU325 CU325RD	C400TM C400TMS	CU400	CU500	CU400M CU400MRD	CU500M CU500MRD	CU580M CU580MRD
1	3-JAW SELF-CENTERING CHUCK	Diameter (mm)	160	200	250	250	250	250	250
2	INDEPENDENT 4-JAW CHUCK	Diameter (mm)	250	320	400	500	400	500	500
3	FACE PLATE	Diameter (mm)	296	320	400	480	400	480	480
4	FOLLOWER REST	Range (mm)	10-70	10-80	15-160	15-200	15-160	15-200	15-200
5	STEADY REST, SMALL SIZE	Range (mm)	10-70	10-100	15-150	15-160 /45-160/	15-160	15-160	15-200
6	STEADY REST, BIG SIZE	Range (mm)	No	No	No	140-280	No	140-280	180-340
7	TAPER TURNING ATTACHM.	$\pm 10^\circ$	Yes	Yes	Yes	Yes	Yes	Yes	Yes
8	ONE-POSITION LONG. STOP		Yes	Yes	Yes	Yes	Yes	Yes	Yes
9	THREAD DIAL		Yes	Yes	Yes	Yes	Yes	Yes	Yes
10	DRIVE PLATE FOR SPINDLE NOSE DIN 55027		Yes	Yes	Yes	Yes	Yes	Yes	Yes
11	SET OF LATHE DOGS	$\varnothing 20$; $\varnothing 30$; $\varnothing 40$; $\varnothing 50$; $\varnothing 60$; $\varnothing 80$; $\varnothing 100$	20; 50;	20;30;40;50;60	Full	Full	Full	Full	Full
12	LIVE CENTER	Morse	M3	M4	M5	M5	M5	M5	M5
13	DRILL CHUCK WITH ARBOR	Drill diam. (mm)	20	20	20	20	20	20	20

Remarks : Yes = Available for this model; No = Not available for this model

Steady rest $\varnothing 720$ mm for lathe CU1000 – open type only

Steady rest $\varnothing 700$ -1000 for lathe CU1410RD - open type only

Steady rest size placed in // refers to the model with rolling quills

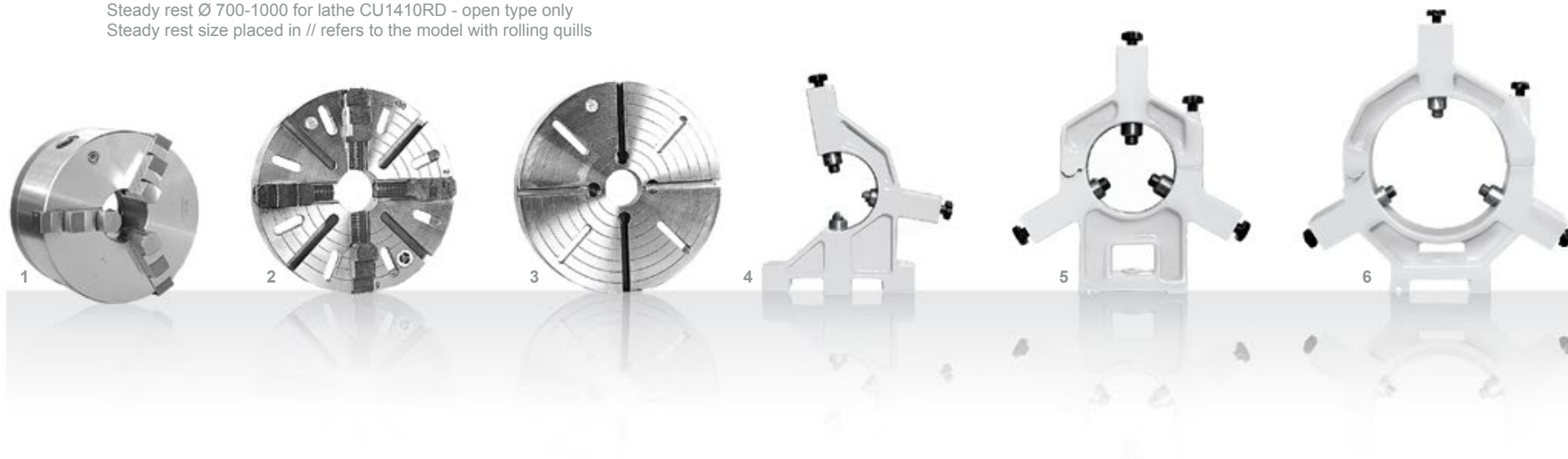

C11MT C11MTS	CU500MT CU500MTRD	CU630 CU630RD	CU730 CU730RD	C10T C10TS	C10TM C10TMS	C10TH C10THS	C10T.10 C10TS.10	C10T.12 C10TS.12	C10T.14	CU800 CU800RD	CU1000 CU1000RD	CU1250 CU1250RD	CU1410RD
250	315	315	315	315	400	400	500	500	660	500	500	500	630
500	500	600	600	600	760	760	580 Standard	630 Standard	710 Standard	760	1000	1000	1250
480	500	600	600	600	760	760	x	x	x	760	1000	1000	No
15-200	15-200	15-200	15-200	20-200	20-200	20-200	20-200	20-200	20-200	80-300	80-300	80-300	80-300
15-200	15-160	15-200	15-200	20-200	20-200	50-250	20-200	20-200	20-200	50-300	50-300	50-300	80-300
180-340	140-280	180-340	180-430	180-430	180-430 200-520	220-450 420-620	180-430	180-430	180-430	270-520	270-520 480-720	270-520 480-720 700-950	270-520 470-720 700-1000
Yes	Yes	Yes	Yes	Yes	Yes	Yes	Yes Standard	Yes Standard	Yes Standard	Yes	Yes	Yes	Yes
Yes	Yes	Yes	Yes	Yes	Yes	Yes	Yes	Yes	Yes	No	No	No	Yes
Yes	Yes	Yes	Yes	Yes	Yes	Yes	Yes Standard	Yes Standard	Yes Standard	Yes	Yes	Yes	No
Yes	Yes	Yes	Yes	Yes	Yes	Yes	No	No	No	No	No	No	No
Full	Full	Full	Full	Full	Full	Full	No	No	No	No	No	No	No
M5	M5	M5	M5	M6	M6	M6	M6	M6	M6	M6	M6	M6	MK 7
20	20	20	20	20	20	20	No	No	No	No	No	No	No



ZMM SLIVEN



ZMM Sliven is specialized in the design and manufacture of universal metal cutting lathes, CNC lathes, equipment and spare parts. Over 95% of the output is exported to more than 80 countries across the globe. Each machine is manufactured as per the specific climate conditions of the region where it will be operated and in consideration of the particular needs of every individual client. Products of ZMM Sliven are recognized all over the world for their long working life and quality. For the time-being, the factory has manufactured a total of over 115,000 lathes.

ZMM Sliven has adopted a comprehensive quality management system and is ISO 9001 certified. All products of ZMM Sliven also bear the CE indication as proof of conformity with the norms and requirements of the European Community.

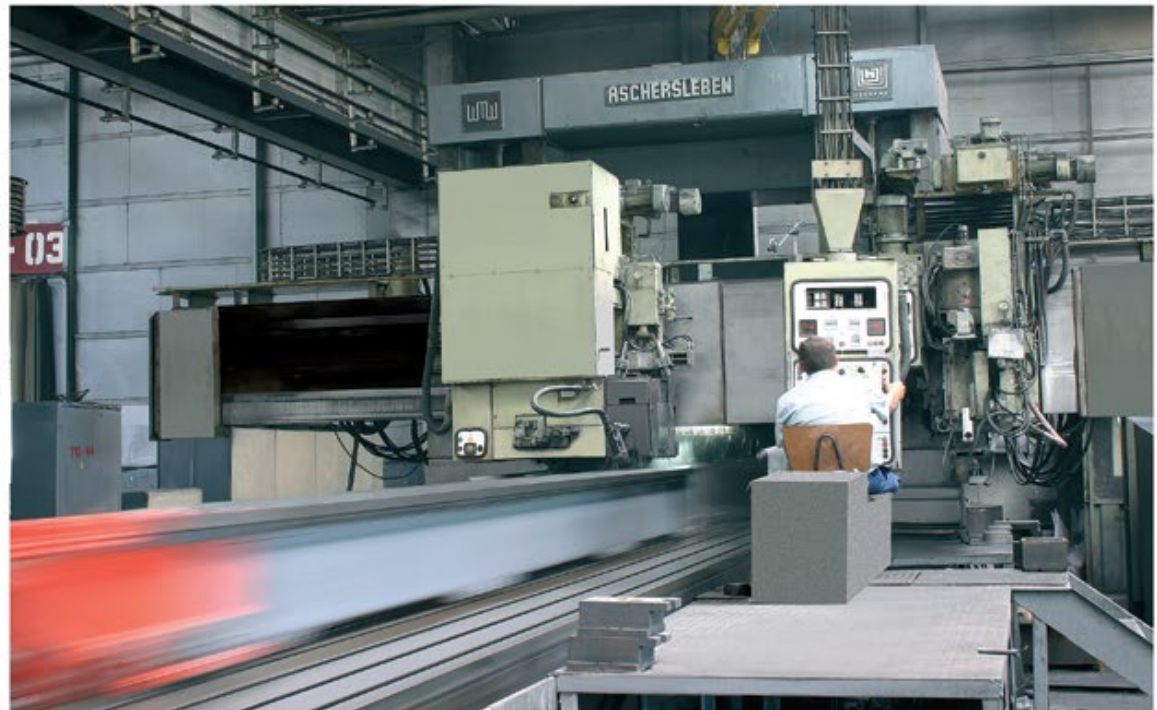

ZMM NOVA ZAGORA

tel.:+359 457 630 56
www.zmmnz.com

ZMM Nova Zagora supplies parts and units to over 30 metal- and woodworking machine manufacturers in Europe. ZMM Nova Zagora's products and services are organized in four groups:

- **ROTATION PARTS:** Axes and shafts - smooth and spline; Gear-wheels; Shaft-gear wheels; Chain gear-wheels, Tooth-belt pulleys, Piston rods;
- **UNITS:** Multi-disk clutches; Lathe gear and slide box ; Cylindrical and worm reduction gear;



- **MACHINES:** Chip conveyors; Machines built in automated wood processing complexes;
- **HEAT TREATMENT:** Soft annealing; Inter mediate annealing; Carburize; Nitro carburize; Core hardening; Surface hardening.

ZMM Nova Zagora is the county's leading manufacturer of chip conveyors for various CNC lathes and centers. They are designed as per customer's specifications using metal hinged bands with fluted working space to transport chips with various shapes.

As of 1998 ZMM Nova Zagora is duly certified and operates as per the ISO 9001 Quality Management System.

IHB Metal Castings

tel.: +359 2 836 44 02
www.ihbmetalcastings.com



IHB Metal Castings is a joint stock company with majority shareholder ZMM Bulgaria Holding. The foundry is specialized in the production of castings from modified gray cast iron - according to EN 1561 and nodular cast iron - according to EN 1563. Castings can be with medium and high degree of complexity in single and small series with single weights in the following ranges:

- Gray cast iron: from 80 to 8 000 kg per unit;
- Nodular cast iron: from 50 to 3 000 kg per unit;

The foundry is also capable of providing a wide range of wooden patterns and cores with accuracy from GTB17 to GTB18 according to DIN1685.

IHB Metal Castings supplies a large variety of castings including the full range of components for machine tools - bodies, bed slides, columns, tailstocks, boxes etc.



Type	Swing over bed	Swing over cross slide	Swing in gap	Spindle bore	Width of bed	Max RPM			Distance between centers												Page			
						Universal	Variable	CNC							For Variable Speed types									
CU325/CU325 RD	325	190	440	32	200	2000	2200	–	500	750	1000													5/21
C400 TM	400	235	550	52	320	2240	–	–		750	1000	1500												7
C400TS	400	235	550	52	320	–	2120	–		750	1000	1500												23
CU400	440	230	620	62	360	2000	–	–			1000	1500	2000											9
CU500	500	300	670	62	360	2000	–	–			1000	1500	2000											9
CU400M/CU400MRD	440	240	640	72	400	2000	2000	–			1000	1500	2000	3000	4000	5000								11/25
CU500M/CU500MRD	500	300	700	72	400	2000	2000	–			1000	1500	2000	3000	4000	5000								11/25
CU580M/CU580MRD	580	380	780	72	400	2000	2000	–			1000	1500	2000	3000	4000	5000								11/25
C11MT/C11MTS	600	400	800	80	400	2000	2000	–			1000	1500	2000	3000	4000	5000								13/27
CU500MT/CU500MTRD	500	300	700	103	400	1400	1400	–			1000	1500	2000	3000	4000	5000								15/29
CU630/CU630RD	630	430	830	103	400	1250	1250	–			1000	1500	2000	3000	4000	5000								15/29
CU730/CU730RD	730	500	930	103	400	1250	1250	–			1000	1500	2000	3000	4000	5000								15/29
C10T/C10TS	660	420	850	103	560	1320	1320	–				1500	2000	3000	4000	5000	6000							17/31
C10TM/C10TMS	760	520	950	132	560	1015	1015	–				1500	2000	3000	4000	5000	6000							17/31
C10TH/C10THS	860	620	1050	132	560	1015	1015	–				1500	2000	3000	4000	5000	6000							17/31
CU800/CU800RD	890	490	1050	155	700	1250	1000	–				1500		3000	4000	5000	6000	7000	8000	9000	10000			19/33
CU1000/CU1000 RD	1090	690	1250	155	700	1250	1000	–				1500		3000	4000	5000	6000	7000	8000	9000	10000			19/33
CU1250/CU1250 RD	1320	940	1500	155	700	1000	1000	–				1500		3000	4000	5000	6000	7000	8000	9000	10000			19/33
CU1410RD	1410	1000	–	205	800	–	500	–					2000	3000	4000	5000	6000	7000	8000	9000				35
LT 580	580	380	–	72	400	–	ranges 3	2000			1000	1500	2000	3000	4000	5000								41
LT660	660	420	–	103	560	–	ranges 3	1320				1500	2000	3000	4000	5000	6000							43
LT 760	760	520	–	132	560	–	ranges 3	1015				1500	2000	3000	4000	5000	6000							43
LT 860	860	620	–	132	560	–	ranges 3	1015				1500	2000	3000	4000	5000	6000							43
LT 800/LCC 800	890	490	–	155	700	–	ranges 4/2	1000/700				1500		3000	4000	5000	6000							47/49
LT 1000/LCC 1000	1090	690	–	155	700	–	ranges 4/2	1000/700				1500		3000	4000	5000	6000							47/49
LT 1250/LCC 1250	1320	940	–	155	700	–	ranges 4/2	1000/700				1500		3000	4000	5000	6000							47/49
Oil country lathes																								
C10T10/LTC10T.10	800	560	990	260	560	400	ranges 4	400				1500	2000	3000	4000	5000	6000							37/45
C10T12/LTC10T.12	800	560	990	315	560	400	ranges 4	400				1500	2000	3000	4000	5000	6000							37/45
C10T14	1020	780	1210	358	560	315	–	–				1500	2000	3000	4000	5000	6000							39



37A Fridtjof Nansen Str., fl.8
1142 Sofia, Bulgaria
tel.: +359 2 980 12 38, 981 07 53, 981 15 06
fax: +359 2 981 43 14
e-mail: office@zmmbulgaria.com
www.zmmbulgaria.com

37A Fridtjof Nansen Str., fl.7
1142 Sofia, Bulgaria
tel.: +359 2 980 71 01, 981 55 06
fax: +359 2 980 70 72
e-mail: office@bulgariaholding.com
www.bulgariaholding.com

