

Thread production on machining centers with constant speed tapping

CNC-Attachments



CST Constant Speed Tapping relies on a compact tapping attachment to provide tap reversal. The machine spindle runs in one direction at the exact programmed speed and reversal occurs within the tapping attachment instantaneously upon machine retraction. This avoids the inevitable RPM fluctuations which occur with reversal of the machine spindle. Benefits include the following...

Reduced Cycle Time

By eliminating the machine spindles need to decelerate, stop, reverse and reaccelerate twice for each tapped hole the tapping time is dramatically reduced.

Longer Tap Life, Improved Thread Quality

Constant speed tapping means that the tap is allowed to cut at the optimum speed continuously without deceleration at the bottom of the hole. The result is the longest tap life and improved thread quality.

Reduced Machine Spindle Wear

Tapping is the only operation requiring machine reversal. Using a Constant Speed Tapping Head eliminates this strain on the machine.

Reduced Energy Costs of up to 75 %

CST attachments reduce the energy costs required by machine spindle reversal by 75%.

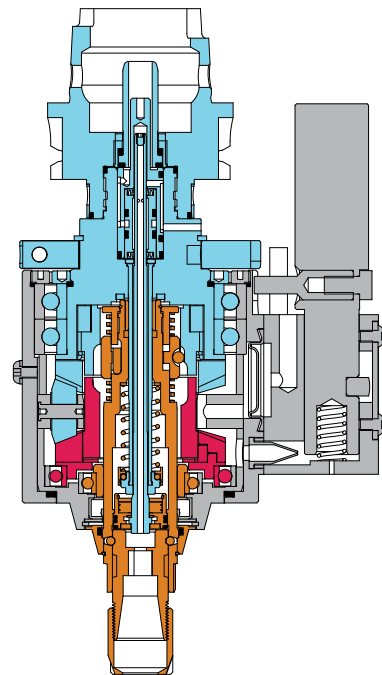

Two Through the Spindle Lubrication Options...

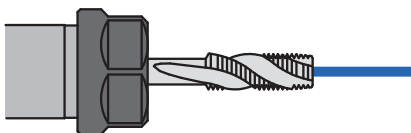

Standard balanced high pressure coolant through the spindle.

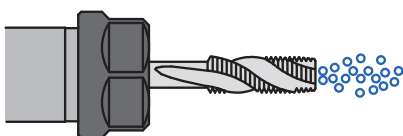

Minimum Quantity Lubrication, available on request.

Patented Design

TAPMATIC tapping attachments include a patented reversing ball drive. The ball drive allows for an exact and immediate change over into reverse once the desired thread depth is reached.

Advantages of tapping attachments with automatic reversal

General Information

Thread cutting is the only machining operation which requires a change of direction for the retraction of the tool. Reversing the spindle causes wear and is a costly procedure for any machine.

RCT and RDT tapping attachments

These reversing tapping attachments are specially designed for fast thread production on CNC machining centers. They eliminate reversal related machine wear and tear and reduce energy consumption. The patented ball drive with integrated planet gear for automatic reversal creates an almost constant cutting speed and eliminates the need to stop and reverse the machine spindle twice per tapped hole.

By using the RDT and RCT tapping attachments the cycle time is reduced and the life of the tap is increased. The IC-version allows coolant to flow directly through the tapping head.

Case history:

Original Application

Thread cutting on a horizontal machining center Fritz Werner TC800 with internal coolant.

Material

GG20

Tap

M6 standard thread HSS with TIN-AL coating

Thread

M6 standard thread, 9 mm deep, tapping drill \varnothing 5.05 and 12.5 mm deep

Speed with machine reversal

Rigid tapping with spindle reversal, programmed speed 1,200 RPM

Original Results

Cycle time of 6 min 34 sec for 68 threads

Change with TAPMATIC

Using a TAPMATIC tapping attachment RDT-IC50 with ER16 spindle, programmed speed 1,800 RPM.

Improvement

Cycle time reduced to 3 min 22 sec for 68 threads, tap life tripled.

Advantage

Besides reducing the cycle time, tap life was considerably increased.

Results

- reduction of cycle time by 50%
- increase of production capacity
- tap life tripled
- less machine wear (no spindle reversals)
- roughly 75% energy savings by constant speed tapping

Constant speed tapping – the secret of longer tap life

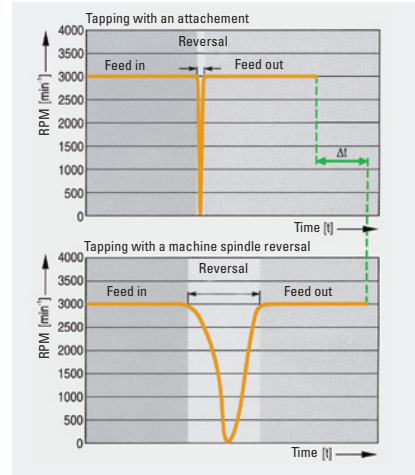

Power consumption for 144 threads M8

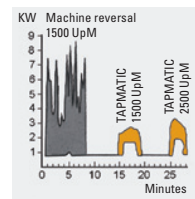

Energy cost saving of 75 %

Not only is the shorter cycle time of importance, but also the constant spindle direction. By changing the direction (decelerating and accelerating) of the spindle, higher spikes of power are needed, which can be prevented by constant spindle rotation.

Total cost/year

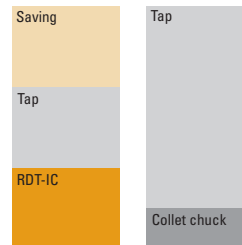

Break Even Point

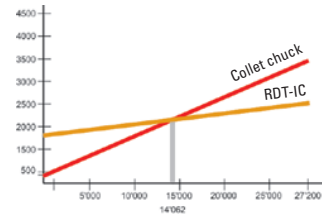

Conclusion

With the use of Tapmatic constant speed tapping, the cycle time is less, which increases productivity. Additionally, machine repair / downtime and energy costs are reduced and tap life is dramatically improved.

High speed tapping attachments with integral HSK shank and internal coolant system

CNC-Attachments

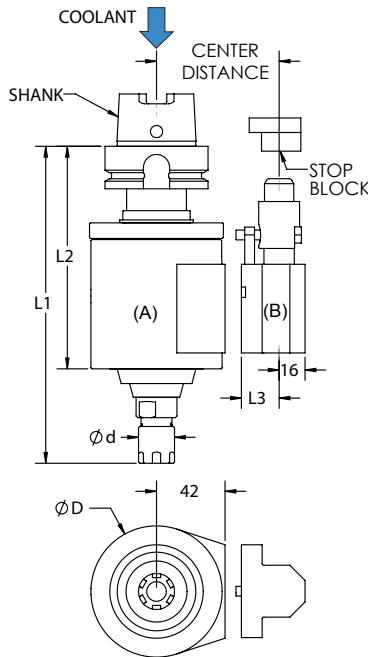

Features and Advantages

- high speed self-reversing tapping for fastest cycle time
- rugged design for years of production, with little maintenance
- high pressure internal coolant system, 50 Bar
- simple installation and programming

How to Order

Please select the Tapping attachment (A) and stop arm (B) to fit your machine. Accessories like steel collets, sealing gaskets and stop blocks are not included. Please order these separately.

Tapmatic can provide a complete tool ready to fit your machine. Please simply provide the information shown on installation page 55, fill in the form on the back cover or contact us directly.



(A) Tapping Attachment RCT HSK

Model	Order code	Capacity (steel)	Shank	Collets	Max. RPM	Weight kg	D	d	L1	L2			
RCT50	0550H63161	M4.5–M12 #10–1/2"	HSK63A	ER16	2500	3.5	80	22	194	136			
	0550H80161		HSK80A						199	141			
	0550H100161		HSK100A	201					143				
	0550H63201	M10–M20 7/16"–3/4"	HSK63A	ER20		2300			3.5	80	28	206	136
	0550H80201		HSK80A									211	141
	0550H100201		HSK100A	213								143	
RCT85HS	0585H6325	M10–M20 7/16"–3/4"	HSK63A	ER25	1500		4.2	80*	42			217	168
	0585H8025		HSK80A									222	173
	0585H10025		HSK100A									224	175
RCT85HD	0585H6332	M12–M25 1/2"–1"	HSK63A	ER32	1200	4.4	80*	50	223	168			
	0585H8032		HSK80A						228	173			
	0585H10032		HSK100A						230	175			
RCT100	05100H6340	M18–M27 3/4"–1"	HSK63A	ER40	800	4.6	80*	63	229	168			
	05100H8040		HSK80A						234	173			
	05100H10040		HSK100A						236	175			

Notes: These internal coolant tools come standard with sealing nuts. These models are also available without internal coolant upon request. When using Roll Form Taps the tool's capacity must be reduced 25%. All dimensions are shown in mm. 25.4mm = 1"

*Please note that size 85 and 100 tools have an 80mm square housing with ø102mm across corners

(B) Stop Arm Assembly

Center Distance (42+L3)	Order code RCT50	Order code RCT85, 100	L3
55	0550551	3985551	13
65	0550651	3985651	23
80	0550801	3985801	38



Stop Block
Page 55

Page 45-47

Page 48

Pages 52-54

Pages 55



Steel Collets



Sealing Gaskets



Speed Chart



Installation

Extended length tapping attachments with integral HSK shank and internal coolant system

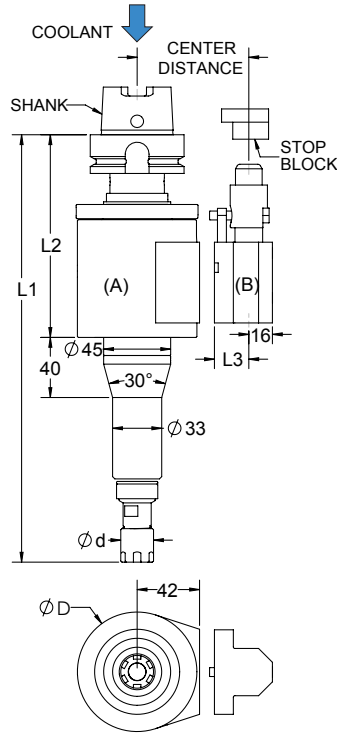

Features and Advantages

- high speed self-reversing tapping for fastest cycle time
- extended length for difficult to reach holes
- rugged design for years of production, with little maintenance
- RCTXT50 for high pressure internal coolant, 50 Bar
- simple installation and programming

How to Order

Please select the Tapping attachment (A), and stop arm (B) to fit your application. Accessories like steel collets, sealing gaskets and stop blocks are not included. Please order these separately.

Tapmatic can provide a complete tool ready to fit your machine. Please simply provide the information shown on installation page 55, fill in the form on the back cover or contact us directly.

(A) Tapping Attachment RCTXT50 HSK Shank, Internal Coolant System



Model	Order code	Capacity (steel)	Shank	Collets	Max. RPM	Weight kg	D	d	L1	L2		
RCTXT50	0550H6316L287	M4.5-M12	HSK63A	ER16	1800	4.0	80	22	287	136		
	0550H8016L292	#10-1/2"	HSK80A			4.4			292	141		
	0550H10016L294	HSK100A	5.3			294			143			
	0550H6320L297	HSK63A	ER20	1600		4.0			80	28	297	136
	0550H8020L302	HSK80A		4.4		302			141			
	0550H10020L304	HSK100A		5.3		304			143			
	0550H6316L360	HSK63A	ER16	1600		4.2			80	22	360	136
	0550H8016L365	HSK80A				4.6					365	141
	0550H10016L367	HSK100A				5.5					367	143
0550H6320L370	HSK63A	ER20	1400		4.2	80	28	370			136	
0550H8020L375	HSK80A				4.6			375			141	
0550H10020L377	HSK100A				5.5			377			143	

Notes: Special extended length tools are also available on request. These models are also available without internal coolant on request. When using Roll Form Taps the tool's capacity must be reduced 25%. All dimensions are shown in mm. 25.4mm = 1"

(B) Stop Arm Assembly



Center Distance (42+L3)	Order code RCT50	L3
55	0550551	13
65	0550651	23
80	0550801	38



Stop Block
Page 55

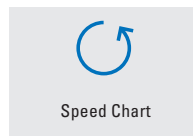

High speed tapping attachments with modular straight shank and internal coolant system or without internal coolant, (W/O IC)

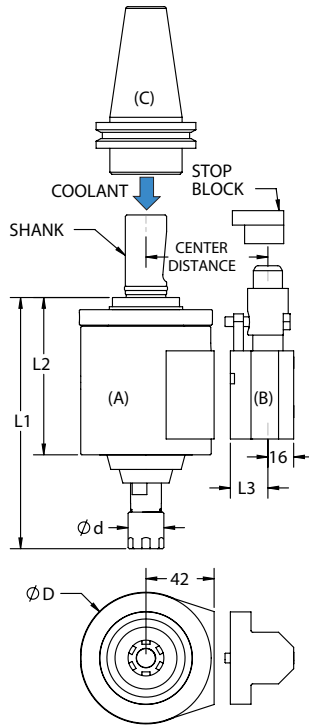

Features and Advantages

- high speed self-reversing tapping for fastest cycle time
- rugged design for years of production, with little maintenance
- high pressure internal coolant system, 50 Bar
- simple installation and programming

How to Order

Please select the Tapping attachment (A) and stop arm (B) and CAT, SK or BT shank (C) to fit your machine. Accessories like steel collets, sealing gaskets and stop blocks are not included. Please order these separately.

Tapmatic can provide a complete tool ready to fit your machine. Please simply provide the information shown on installation page 55, fill in the form on the back cover or contact us directly.

(A) Tapping Attachment RCT Cylindrical Shank



Model	Order code	Capacity (steel)	Shank	Collets	Max. RPM	Weight kg	D	d	L1	L2	Order Code W/O IC	L1 W/O IC
RCT50	05502516	M4.5–M12	25 mm	ER16	2500	3.0	80	22	155	97	04502516	152
	05501116	#10–1/2"	1"								04501116	
	05502520		25 mm	ER20	2300		80	28	167	97	04502520	162
RCT85HS	0550120		1"								0450120	
	05852525	M10–M20	25 mm	ER25	1500	3.7	80*	42	168	119	04852525	163
RCT85HD	0585125	7/16"–3/4"	1"								0485125	
	05852532	M12–M25	25 mm	ER32	1200	3.9	80*	50	174	119	04852532	169
RCT100	0585132	1/2"–1"	1"								0485132	
	051002540	M18–M27	25 mm	ER40	800	4.1	80*	63	180	119	041002540	175
	05100140	3/4"–1"									04100140	

Notes: These internal coolant tools come standard with sealing nuts. These models are also available without internal coolant upon request. When using Roll Form Taps the tool's capacity must be reduced 25%. All dimensions are shown in mm. 25.4mm = 1".

* Please note that size 85 and 100 tools have an 80mm square housing with ø102mm across corners.

(B) Stop Arm Assembly



Center Distance (42+L3)	Order code RCT50	Order Code RCT 85, 100	L3
55	0550551	3985551	13
65	0550651	3985651	23
80	0550801	3985801	38



Stop Block
Page 55

Page 50

Pages 45-47

Page 48

Pages 52-54

Pages 55



(C)
Interchangeable Steep Taper



Steel Collets



Sealing Gaskets



Speed Chart



Installation

Extended length tapping attachments with modular straight shank and internal coolant system or without internal coolant, (W/O IC)

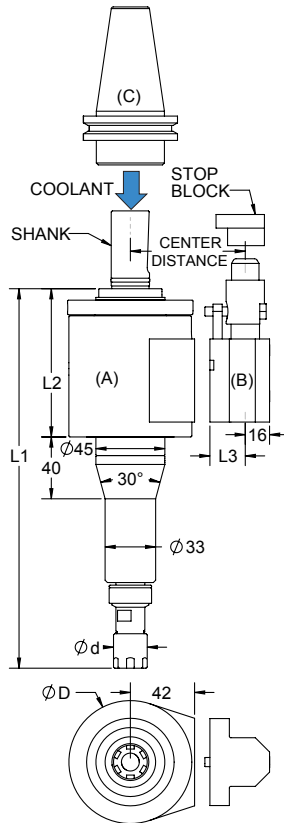

Features and Advantages

- high speed self-reversing tapping for fastest cycle time
- extended length for difficult to reach holes
- rugged design for years of production, with little maintenance
- RCTXT50 for high pressure internal coolant, 50 Bar
- simple installation and programming

How to Order

Please select the Tapping attachment (A), stop arm (B), shank (C) to fit your application. Accessories like steel collets, sealing gaskets and stop blocks are not included. Please order these separately.

Tapmatic can provide a complete tool ready to fit your machine. Please simply provide the information shown on installation page 55, fill in the form on the back cover or contact us directly.

(A) Tapping Attachment RCTXT50 Cylindrical Shank, Internal Coolant System



Model	Order code	Capacity (steel)	Shank	Collets	Max. RPM	Weight kg	D	d	L1	L2	Order code W/O IC	L1 W/O IC
RCTXT50	05502516L248	M4.5-M12	25 mm	ER16	1800	3.5	80	22	248	97	04502516L245	245
	0550116L248	#10-1/2"	1"		0450116L245							
	05502520L258		25 mm	ER20	1600	3.7		28	258		04502520L253	253
	0550120L258		1"		0450120L253							
	05502516L321		25 mm	ER16	1600			22	321		04502516L318	318
	0550116L321		1"		0450116L318							
	05502520L331		25 mm	ER20	1400			28	331		04502520L326	326
	0550120L331		1"		0450120L326							

Notes: These internal coolant tools come standard with sealing nuts. These models are also available without internal coolant upon request. Special extended length tools are also available on request. When using Roll Form Taps the tool's capacity must be reduced 25%. All dimensions are shown in mm. 25.4mm = 1"

(B) Stop Arm Assembly



Center Distance (42+L3)	Order code RCT50	L3
55	0550551	13
65	0550651	23
80	0550801	38



Stop Block
Page 55

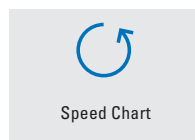

Large capacity tapping attachments with modular straight shank and internal coolant system

The RCT150 is our new, large capacity self-reversing tapping attachment for CNC machining centers. Heavy duty precision gearing transmits high torque for reversing tap sizes up to M42. They are ruggedly built to provide years of service, and include high volume, high pressure internal coolant.

The RCT150 was developed for the large tapping applications required by the wind energy, heavy industry, and power generation fields. By eliminating machine spindle reversal, cycle time is dramatically improved, electrical power consumption is reduced by as much as 75% and wear and tear to the machine spindle caused by stopping and reversing twice for each tapped hole is eliminated.

Features and Advantages

- high speed self-reversing tapping for fastest cycle time
- rugged design for years of production, with little maintenance
- high pressure internal coolant system, 50 Bar
- simple installation and programming

How to Order

Please select the Tapping attachment (A), stop arm (B) and CAT, SK, or BT shank (C), to fit your machine. Accessories like steel collets, sealing gaskets and stop blocks are not included. Please order these separately.

Tapmatic can provide a complete tool ready to fit your machine. Please simply provide the information shown on installation page 55, fill in the form on the back cover or contact us directly.

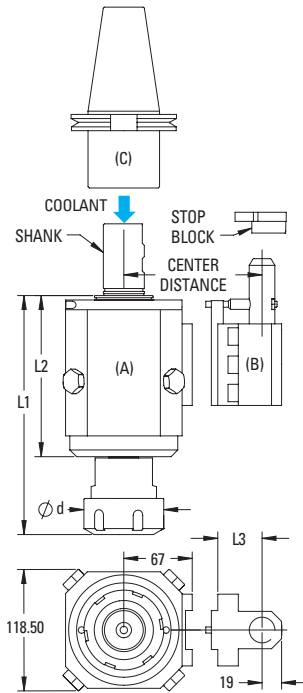

(A) Tapping Attachment RCT150 Cylindrical Shank

Model	Order code	Capacity (steel)	Shank	Collets	Max. RPM	Weight kg	d	L1	L2
RCT150	051504050	M25-M42 1"-1 5/8"	40 mm	ER50	500	6.2	78	234	158

Notes: When using Roll Form Taps the tool's capacity must be reduced 25%.
All dimensions are shown in mm. 25.4mm = 1"



(B) Stop Arm Assembly

Center Distance (67+L3)	Order code RCT150	L3
80	0515080	13
110	05150110	43



Stop Block
Page 55

Page 50

Pages 45-47

Page 48

Pages 52-54

Pages 55



Interchangeable Steep Taper



Steel Collets



Sealing Gaskets



Speed Chart



Installation

High speed tapping attachments with modular straight shank, without internal coolant system

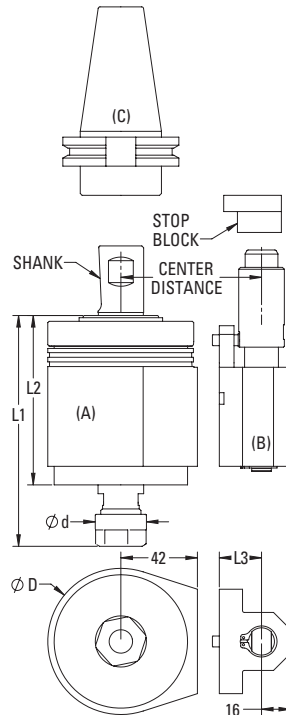

Features and Advantages

- high speed self-reversing tapping for fastest cycle time
- rugged design for years of production, with little maintenance
- simple installation and programming
- large capacity

How to Order

Please select the Tapping attachment (A), stop arm (B) and CAT, SK, or BT shank (C), to fit your machine. Accessories like steel collets, sealing gaskets and stop blocks are not included. Please order these separately.

Tapmatic can provide a complete tool ready to fit your machine. Please simply provide the information shown on installation page 55, fill in the form on the back cover or contact us directly.

(A) Tapping Attachment RDT Cylindrical Shank



Model	Order code	Capacity (steel)	Shank	Collets	Max. RPM	Weight kg	D	d	L1	L2
RDT15	3915258HD	M1-M3	25 mm	ER8	5000	1.7	57	12	97	79
	391518HD	#0-#6	1"							
RDT25	39252511	M2-M6	25 mm	ER11	4000	1.7	57	19	106	79
	39251111	#4-1/4"	1"							
RDT50	39502516	M4.5-M12	25 mm	ER16	2000	3.7	80	28	126	93
	3950116	#10-1/2"	1"							

Notes: When using Roll Form Taps the tool's capacity must be reduced 25%.
To hold larger taps with RDT50 ER16, use standard collet 20953 and separate square drives packaged with tool.
All dimensions are shown in mm. 25.4mm = 1"

(B) Stop Arm Assembly



Center Distance (42+L3)	Order code RDT15	Order code RDT50	L3
55	3925551	3950551	13
65	3925651	3950651	23
80	3925801	3950801	38



Stop Block
Page 55

Page 50

Pages 45-47

Pages 52-54

Pages 55

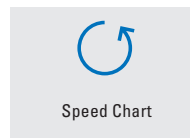
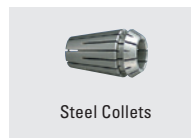

Economical tapping attachments with modular straight shank

The SPD CNC are low cost, self-reversing tapping attachments for CNC machining centers. They use ER collets and employ a simple stop arm system for easy installation on machines with automatic tool change.

The SPD CNC were developed specifically for short run job shop applications. Their low cost make them economical to use, and they provide all the advantages associated with the elimination of machine spindle reversal. Faster cycle time, elimination of machine spindle wear and tear due to reversal, lower energy costs and longer tap life.

Features and Advantages

- faster cycle time
- eliminates machine reversal for lower energy costs and reduced wear to machine spindle
- ER collets
- simple installation with torque bar and stop arm
- Stop Arm Assembly included
- simple programming

How to Order

Please select the Tapping attachment (A) and CAT, SK or BT shank (C) to fit your machine. Please order accessories like collets, and torque bars separately. Please note the tool comes with a stop arm that can be modified or you can also order a readymade stop arm to fit your machine's bolt circle. Torque bar holders are not included and need to be ordered according to the bolt size of your machine.

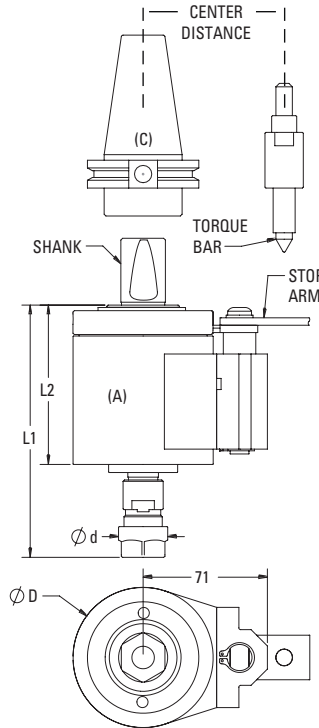

(A) Tapping Attachment SPD CNC Cylindrical Shank



Model	Order code	Shank	Capacity (steel)	Collets	Max. RPM	Weight kg	d	L1	L2
SPD CNC3	0283251152	25 mm	M2-M6	ER11	2000	1.7	19	106	73
	0283111152	1"	#4-1/4"						
SPD CNC5	0285251652	25 mm	M4.5-M12	ER16	1500	3.7	28	140	91
	028511652	1"	#10-1/2"						

Notes: The SPD CNC tools include a stop arm assembly, but it is possible to use the RDT25 and 50 stop arm assemblies with them as well. When using Roll Form Taps the tool's capacity must be reduced 25%. All dimensions are shown in mm. 25.4mm = 1"

Stop Arm Plate



Order code	Center distance mm
723420	53-69
723421	68-77
723422	74-88
723423	86-100



Torque Bar Holder Assemblies

Page 55

Page 50

Pages 45-47

Pages 52-54

Pages 55

(C)



Interchangeable Steep Taper



Steel Collets



Speed Chart



Installation

Tapping attachments with VDI shank for CNC lathes



Model RSR



Model ASR

Features and Advantages

- high speed self reversing tapping for fastest cycle time
- lower energy cost
- improves tap life
- steel collets ER-GB (ER)
- modular base adaptors VDI and BMT, to fit all turrets, provided by EWS

Developed in cooperation with EWS, a world leader in driven tooling for CNC lathes

Radial Tapping Attachment RSR

Model	Order code	Capacity (steel)	Collets ER	Max. RPM (I - O = 1 - .666)
RSR50	37014E1	M4.5–M12	ER16	3300

Axial Tapping Attachment ASR

Model	Order code	Capacity (steel)	Collets ER	Max. RPM
ASR50	32161E	M4.5–M12	ER16	2500

Note: Steel collets and VDI shank have to be ordered separately. The VDI shank is manufactured specifically for your lathe. When using Roll Form Taps the tools capacity must be reduced by 25%. Dimensions for the attachments available on request.

Right angle tapping attachment RSR50 VMC



- self-reversing right angle tapping attachment for machining centers
- capacity: M4.5–M12
- simple installation and programming, suitable for machines with automatic tool change
- automatic reversal for faster cycle time
- lower energy cost
- improves tap life
- eliminates secondary tapping operations
- on request

