

DU10P 50

stroke / corsa

	spindle / mandrino
B1	B12 DIN 238
E2	ER20 DIN 6499
D1	ø16 DIN 55058

	rpm	
	50Hz	60Hz
05	500	600
07	750	900
10	1000	1200
12	1250	1500
15	1500	1800
20	2000	2400
25	2500	3000
30	3000	3600
50	5000	6000
70	7000	8400
90	9000	10800

	motor / motore
036	80-B14 0,37Kw 6 poles
056	80-B14 0,55Kw 6 poles
034	71 B14 0,37Kw 4 poles
054	80 B14 0,55Kw 4 poles
074	80 B14 0,75Kw 4 poles
032	71 B14 0,37Kw 2 poles
052	71 B14 0,55Kw 2 poles
072	80 B14 0,75Kw 2 poles
112	80 B14 1,10Kw 2 poles

	motor type / tipo motore
S	230-400V-50/60Hz
A	brake motor autofrenante
V	forced ventilation servovenilato
AV	brake motor + forced ventilation autofrenante + servovenilato

	hydrocheck / regolatore
45H	standard
45HS	with oil bowl con serbatoio olio
75HP	peck feed scarico trucioli

STANDARD COLOR



OPTIONAL COLORS

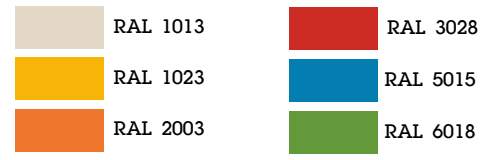

optional :

accessories for easy installation
accessori per una facile installazione

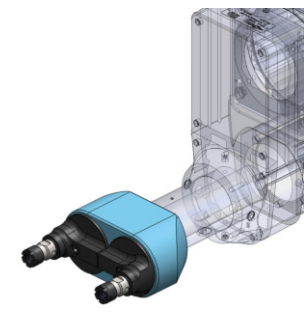
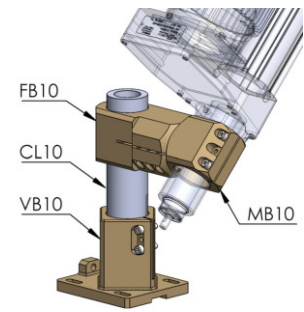
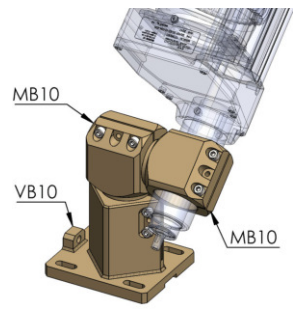
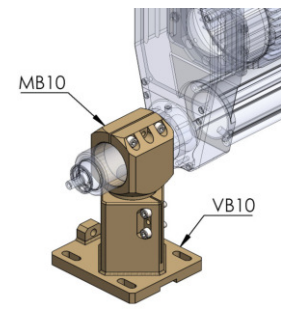
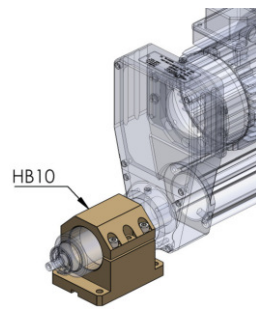

multispindle head
teste multiple

