



Endless Innovation



MAPLE TECHNOLOGY CO.,LTD.
No.3-1, Zhongshan Rd., Shalu Dist.,
Taichung City 43348,
Taiwan R.O.C.
Tel:+886-4-26150200 Fax:+886-4-26153906
Website:www.maple-tech.com.tw

ME—SERIES

High Accuracy.
High Performance.

Introducing the most powerful
ME-Series we ever design.



THE ULTIMATE ALL-ROUNDER.

Every day presents different challenges. Luckily, the Maple ME-Series has what it takes to tackle just about anything: versatility. Its super wide base design provides great balance of the machine and opens up to create a platform capable of supporting up to 800 to 2000 kg. With high-end servo motors that are directly connected to the ball screw not one single ounce of power is lost during transmission.

Just as impressive as the ME-Series performs in mold production with innovative design and cutting-edge technologies make it also very suitable for parts production. In short: the Maple ME-Series has a clever solution for whatever challenge comes its way.

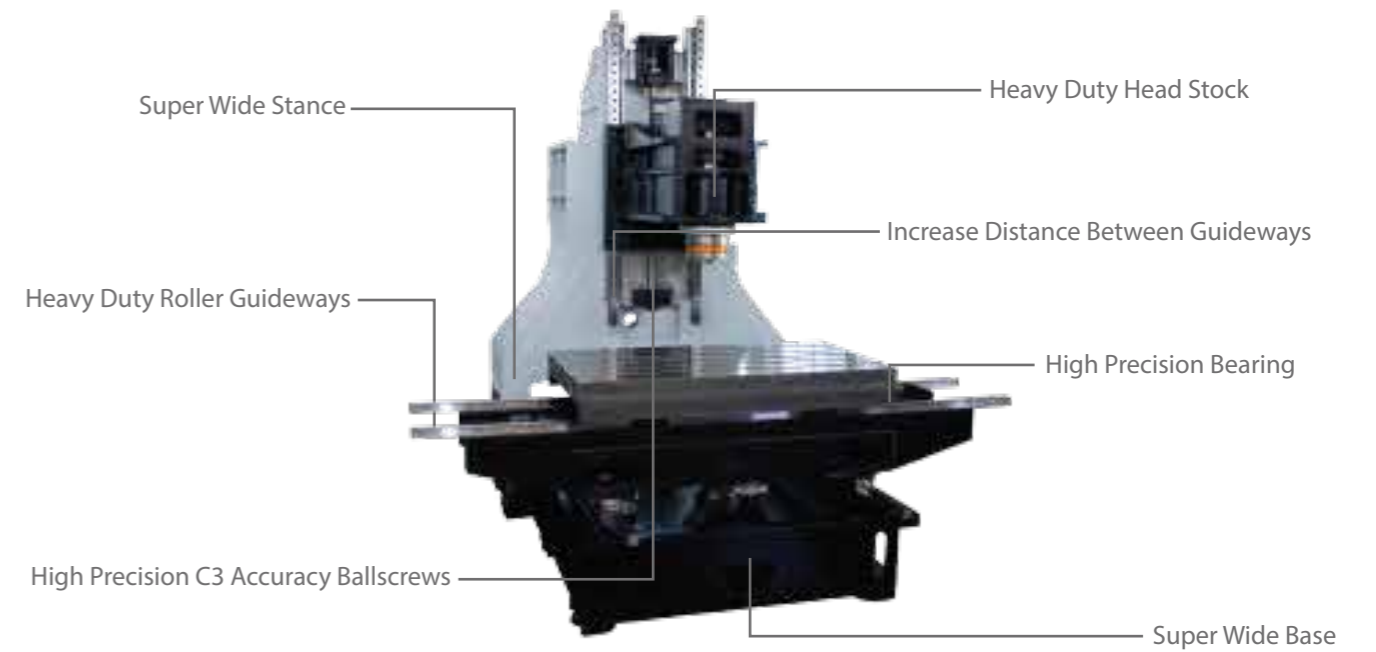

Display 1060/1260 machine body.

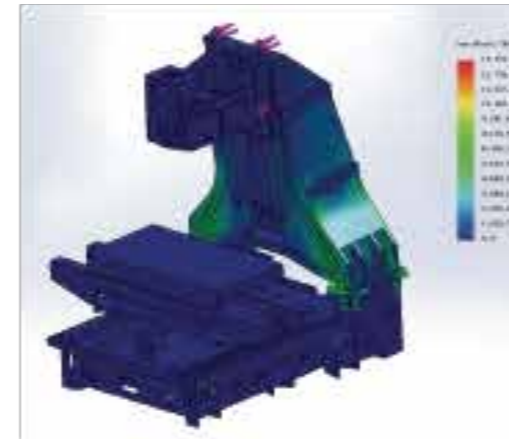

■ Designed with technology

ME-Series was designed with the most advance FEM analysis software on the market. We are able to test our design under many different stressed conditions. This gives us the ability to design the ME-Series machine to not only meet our customers requirements, but to surpass our customers needs. This gives the customer more value because of our design.



■ Separate is better

Many machines face overheating and noise from high voltage amps that are installed in the electronic cabinets. The ME-Series machine was designed to avoid all these problems. By separating all the high voltage from the low voltage parts the machine is able to reduce heat and noise from high voltage units affecting the low voltage units.



■ Swivel-type operation panel

The operation panel which can swivel from 0 degree to 90 degrees improves operability and visibility.

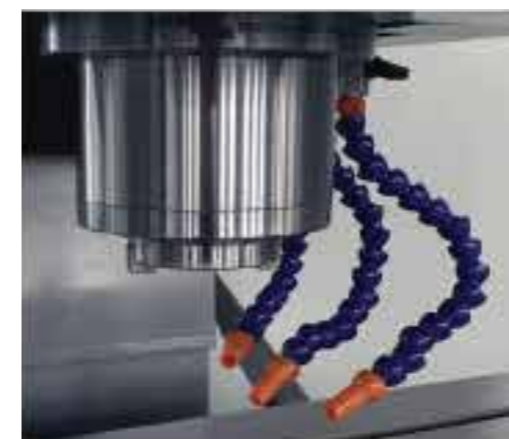

■ High-Capacity Cartridge Spindle

The advanced design of our spindles provides high axial- thrust capability, yet generates minimal heat. The spindle uses front and rear pre-load angular bearing with large spacer to enhance radial stability - enabling heavy cuts on steel. To ensure pro-long life of the spindle, high temperature grease is used to guarantee smooth operation of the spindle regardless of operation temperature.



■ High Speed Tool Changer

Without a tool changer the machine cannot operate at its fully automatic potential. That is why the ME-Series uses nothing but the most high quality tool changer on the market. With a 1.8 second tool change time it is one of the fastest performing tool change on the market.



■ A direct connect servo motor with a brake has been added

The Z-axis motor is equipped with internal brakes. This means the headstock will not lower by itself. Direct connect motor helps reduce back lash and helps create a better responding machine.

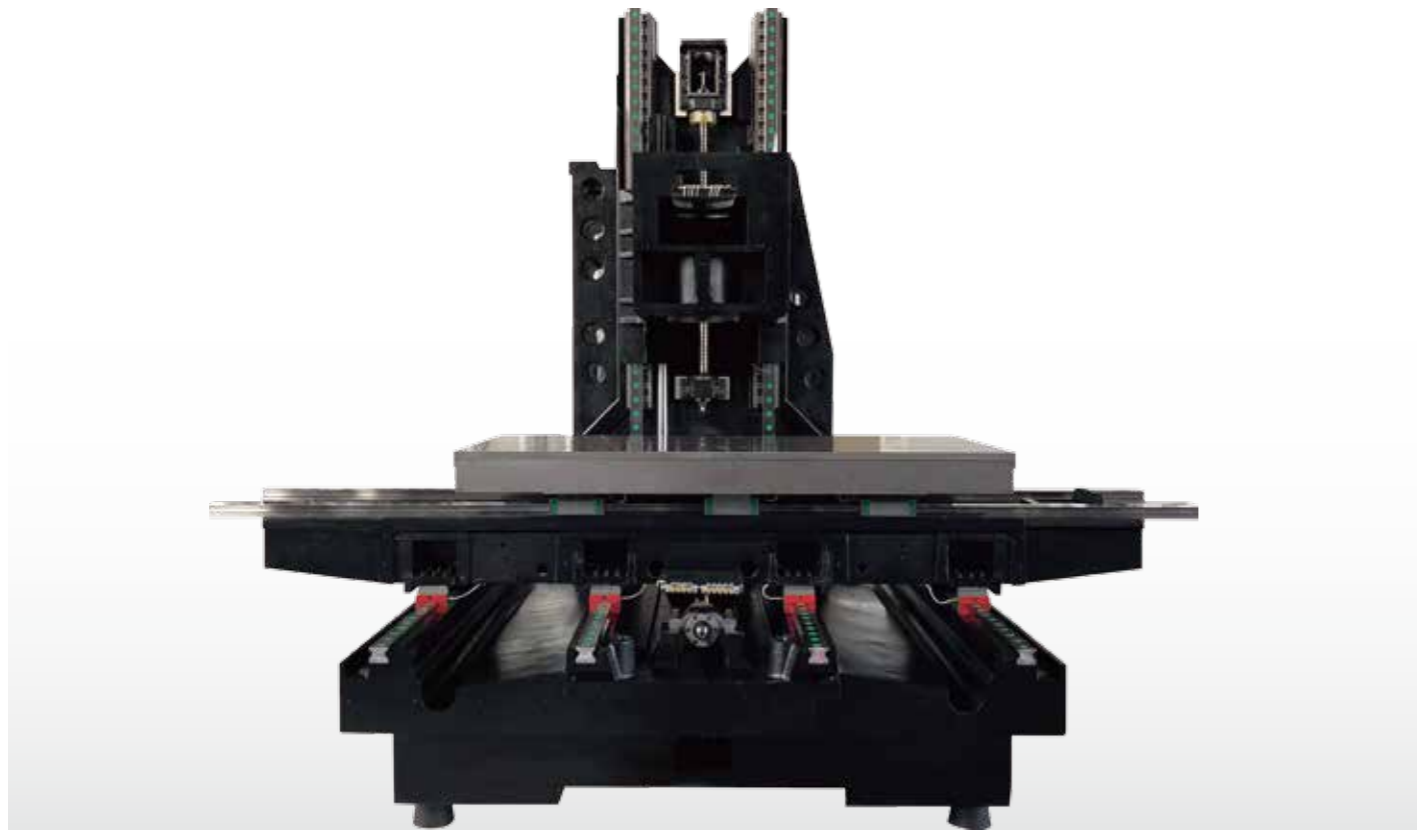

Using the expertise honed over 30 years, the ME-Series is designed to carve through any material it meets-without sacrificing accuracy or finish along the way.



Always in control

We equipped our machine with the most powerful controller on the market. This gives the machine more high speed capability and increase productivity.



Strength in the right places

The ME-Series is designed with larger guideways and more slide blocks compare to other machines in the market. We believe by designing the machine with more then what is needed. The machine is able to cut faster, harder, and have more durability then other machines.

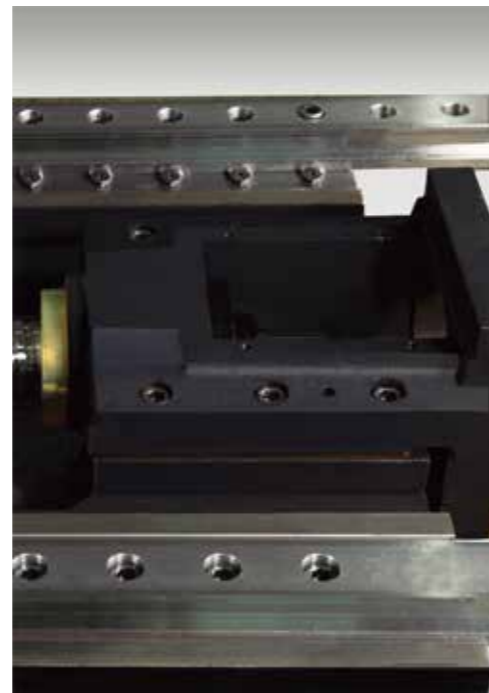

The little things that matter

The most important parts of the machine are the little things that no one ever ask about. With the ME-Series we looked at the little things and made sure it was up to the task. With larger and more bearings per-axis, we were able to give the machine more axis force which enables the machine to have more drilling ability, heavier cutting ability and more smoothness during corning.



Performance Diagrams-Mitsubishi

ME-655/855/1055 Mitsubishi-Drive

ME-1060/1070/1260/1270 Mitsubishi-Drive

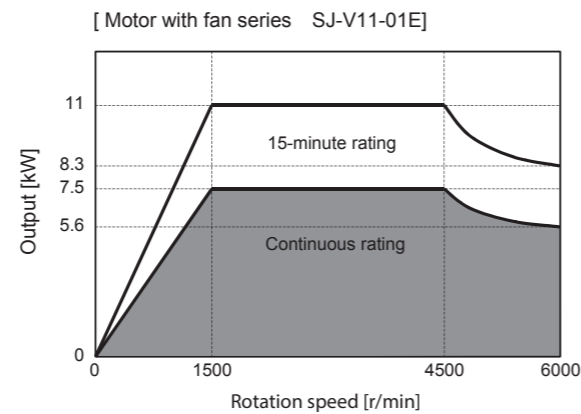
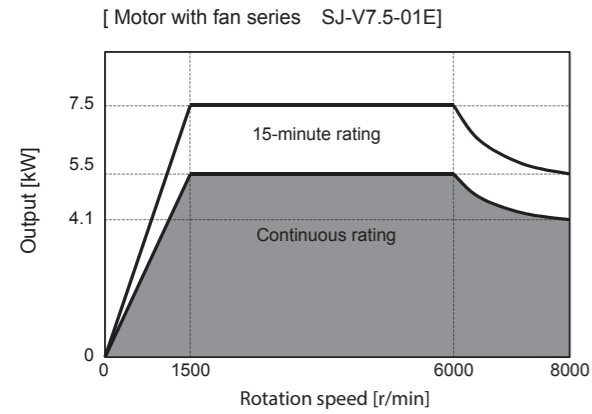

ME-1370/1470/1670/1690/1890/2012 Mitsubishi-Drive

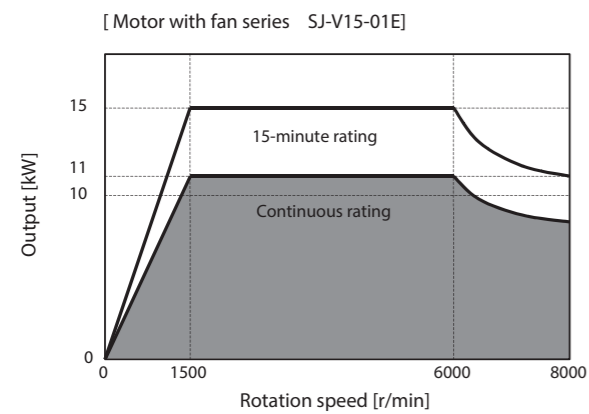

Performance Diagrams-Siemens

ME-655/855/1055 Siemens-Drive

ME-1060/1070/1260/1270 Siemens-Drive

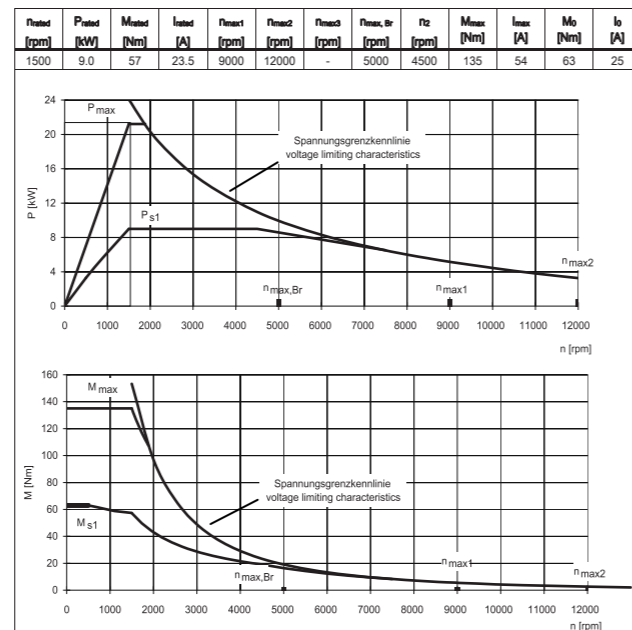
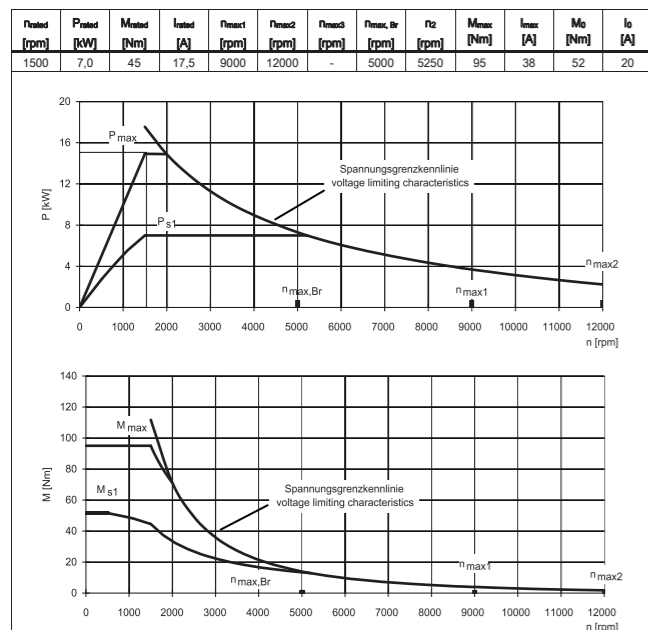

ME-1060/1070/1260/1270 Siemens-Drive Optional

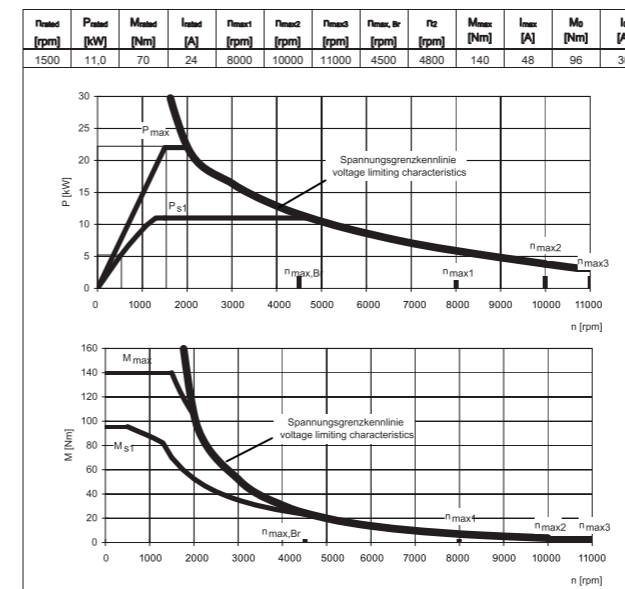

ME-1370/1470/1670/1690/1890/2012 Siemens-Drive

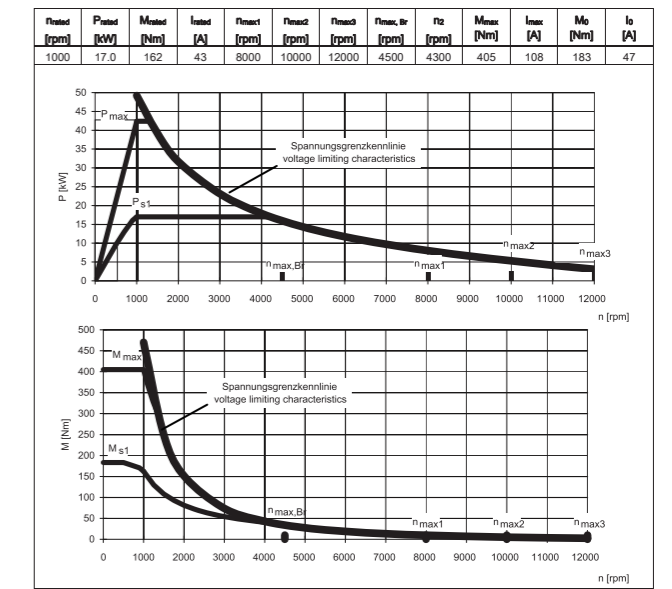

Performance Diagrams-Fanuc

ME-655/855/1055 Fanuc-Drive

ME-1060/1070/1260/1270/1370/1470/1670 Fanuc-Drive

ME-1690/1890/2012 Fanuc-Drive

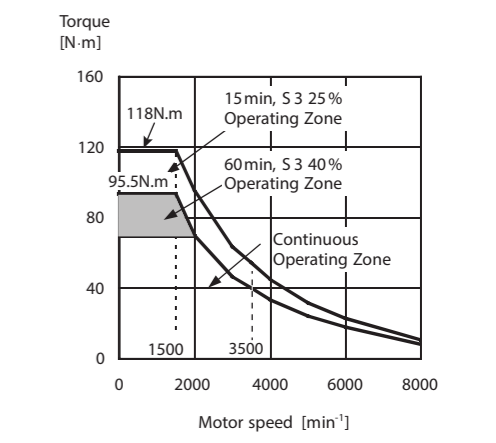
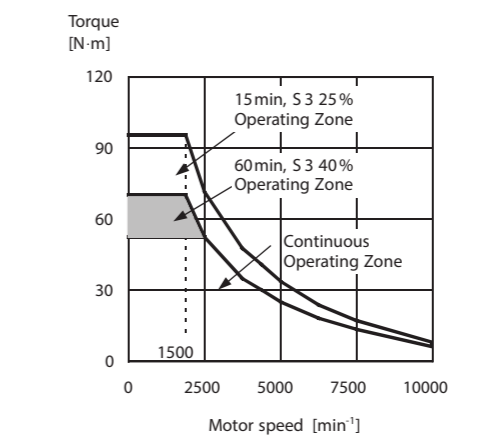
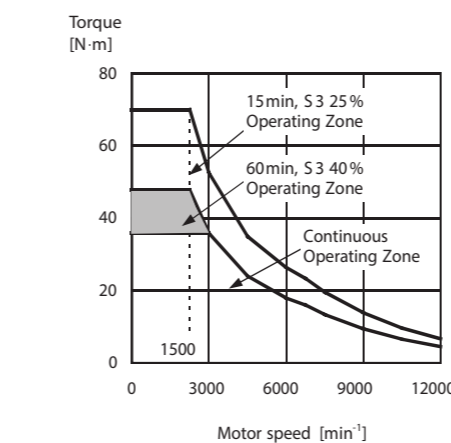
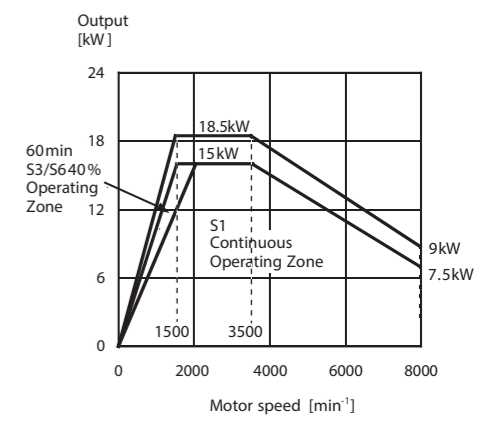
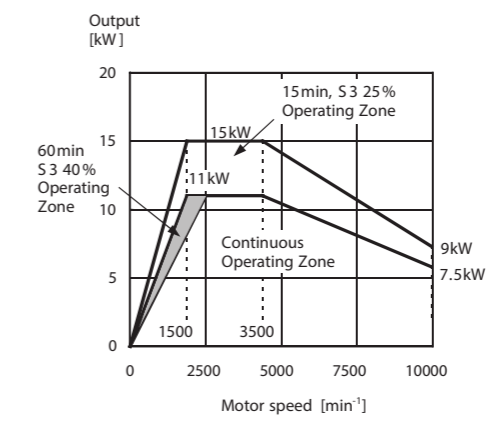
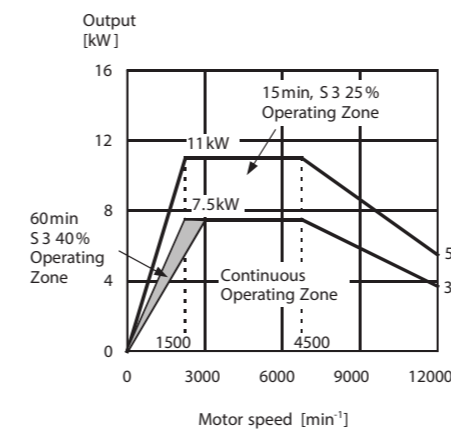

Options

Two-face contact specifications OPTION

Tool rigidity has been improved by contact of both the spindle taper and the tool flange. This extends the useful life of a tool, raises cutting power and improves the machining precision.

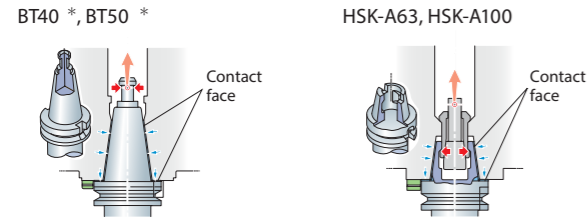

* When the two-face contact specification is selected, a two-face contact tool and other tools cannot be used together.

Through-spindle coolant system OPTION

The through-spindle coolant system effectively eliminates chips, cooling the machine point, and lengthening the lives of your tools.

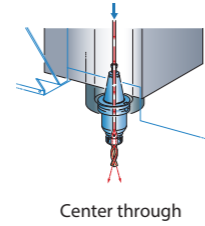

Coolant Pressure:
 - 2 mpa
 - 3 mpa
 - 5 mpa
 - 7 mpa

* The colors and configurations shown in the photographs or illustrations may differ from those of the actual product.

Linear Scale OPTION

The absolute glass linear scale (full closed-loop control) made by HEIDENHAIN is effective for high-precision positioning, and is available as an option.



- High accuracy, high resolution
- Greater accuracy than standard machines
- Highly resistant to condensation and oil
- Vibration and impact resistant characteristics

Workpiece measurement function OPTION

In-machine measuring system (spindle)
 Optical type touch sensor

In-machine measuring system (spindle)
 Inductive type touch sensor

Work setter function (manual measurement application)

- Reference plane measurement
 The machining reference point can be calculated simply by applying the sensor from the Z, X and Y-axis directions.

- Reference hole measurement
 Centering a boss, hole, groove or width can be done at any two or three points, simply by applying the sensor.

- Coordinate rotation measurement
 Machining can be done without changing the program even if the workpiece is attached crookedly, simply by performing this operation within the X-axis and Y-axis plane.

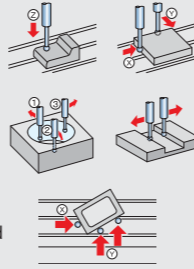

Tool measurement function OPTION

In-machine measuring system (table)
 Touch sensor (tool length)

In-machine measuring system (table)
 Touch sensor (tool length / tool diameter)

Tool setter function (manual measurement application)

- Tool length measurement
 The tool length value can be registered automatically to the designated tool offset number.

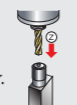

Tool setter function (manual measurement application)

- Tool length measurement
 The tool length value can be registered automatically to the designated tool offset number.

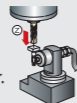

- Tool diameter measurement
 The tool diameter value can be registered automatically to the designated tool offset number.

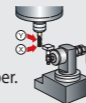

Work Piece Size

ME-Series

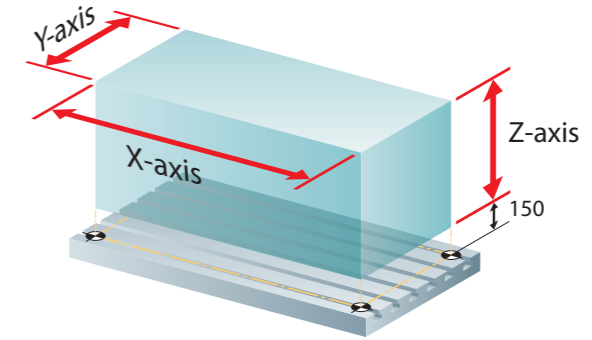

Units	ME-655	ME-855	ME-1055	ME-1060	ME-1070	ME-1260	ME-1270	ME-1370	ME-1470	ME-1670	ME-1690	ME-1890	ME-2012
X-Axis mm	650	850	1000	1000	1000	1200	1200	1300	1400	1600	1600	1800	2000
Y-Axis mm	550	550	550	620	720	600	720	720	720	720	900	900	1200
Z-Axis mm	550	550	550	600	700	600	700	700	700	700	800	800	860

Floor Plans

ME-Series

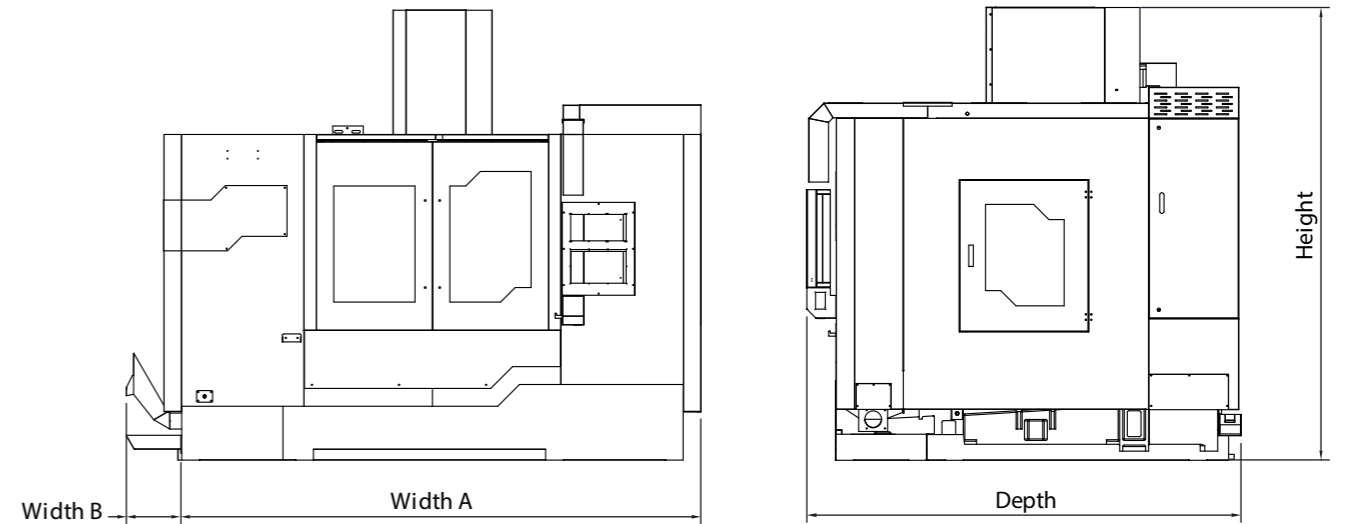

	Units	ME-655	ME-855	ME-1055	ME-1060	ME-1070	ME-1260	ME-1270	ME-1370	ME-1470	ME-1670	ME-1690	ME-1890	ME-2012
Width A	mm	2710	2710	2930	3300	3300	3200	3300	4000	4000	4100	4100	4200	5700
Width B	mm	300	300	330	300	300	300	300	300	300	300	300	300	300
Depth	mm	2400	2400	2420	2620	2620	2620	2620	2750	2750	2800	2800	2850	3900
Height Min	mm	2350	2350	2350	2450	2550	2450	2550	2850	2850	2850	2850	2900	4200
Height Max	mm	2750	2750	2750	2900	3000	2850	3000	3170	3170	3200	3200	3250	4600

Technical Data

	ME-655	ME-855	ME-1055	ME-1060	ME-1070	ME-1260
Table						
Area of Table (mm)	800 x 550	1000 x 550	1100 x 550	1100 x 600	1100 x 700	1300 x 600
Working Area (mm)	650 x 550	850 x 550	1000 x 550	1020 x 600	1000 x 700	1200 x 600
T-Slot (mm)	100 x 18 x 5	100 x 18 x 5	100 x 18 x 5	100 x 18 x 5	100 x 18 x 6	100 x 18 x 5
Work Table Max Weight (kgs)	600	800	800	900	1000	1200
Travel						
X/Y/Z - Axis Travel (mm)	650/550/550	850/550/550	1000/550/550	1020/600/600	1000/720/700	1200/600/600
Spindle Nose to Table surface (mm)	150-700	150-700	150-700	150-750	150-850	150-750
X/Y/Z-Guideway Type	Linear Gindeway	Linear Gindeway	Linear Gindeway	Linear Gindeway	Linear Gindeway	Linear Gindeway
Spindle						
Spindle Taper	BT40	BT40	BT40	BT40/BT50	BT40/BT50	BT40/BT50
Spindle rpm	10000	10000	10000	10000/6000	10000/6000	10000/6000
Transmission Method						
Spindle Motor (kw)-Fanuc	7.5/11	7.5/11	7.5/11	11/15	11/15	11/15
Spindle Motor (kw)-Mitsubishi	5.5/7.5	5.5/7.5	5.5/7.5	7.5/11	7.5/11	7.5/11
Spindle Motor (kw)-Siemens	7	7	7	9	9	9
Spindle Motor (kw)-Heidenhain	7.5	7.5	7.5	10	10	10
Three-Axis Motor						
X/Y/Z-Axis Servo Motor (kw)-Fanuc	1.8/1.8/3.0BS	1.8/1.8/3.0BS	1.8/1.8/3.0BS	3.0/3.0/3.0BS	3.0/3.0/3.0BS	3.0/3.0/3.0BS
X/Y/Z-Axis Servo Motor (kw)-Mitsubishi	1.5/1.5/3.0BS	1.5/1.5/3.0BS	1.5/1.5/3.0BS	3.0/3.0/3.0BS	3.0/3.0/3.0BS	3.0/3.0/3.0BS
X/Y/Z-Axis Servo Motor (kw)-Siemens	2.85/2.85/3.55BS	2.85/2.85/3.55BS	2.85/2.85/3.55BS	3.55/3.55/3.55BS	3.55/3.55/5.5BS	3.3/3.3/5.5BS
X/Y/Z-Axis Servo Motor (kw)-Heidanhain	2.9/2.9/3.9BS	2.9/2.9/3.9BS	2.9/2.9/3.9BS	3.9/3.9/3.9BS	3.9/3.9/4.6BS	3.9/3.9/4.6BS
3-Axis Cutting Feed Rate (mm/min)	10000	10000	10000	10000	10000	10000
3-Axis Rapid Traverse (m/min)	36/36/36	36/36/36	36/36/36	36/36/36	24/24/24	36/36/36
Others						
Machine Weight / Gross Weight (kgs)	4000	5200	5500	6200	6200	6500
Control						
ME-Series Control	Fanuc Oi-MF/31i, Mitsubishi M80A/M80B, Siemens 828D/840D, Heidenhain TNC620/TNC640					

Standard

- Enclosed Guard
- Swiveling Control Box
- Low Energy Work Light
- LED 3 Color Warning Light
- Volumetric Type Automatic Lubricator
- Auto Power Off
- Rigid Tapping
- Tool Box
- Leveling Screws & Blocks
- Operation Manual
- Air Gun
- Mechanical Oil Coolant Separator

Technical Data

	ME-1270	ME-1370	ME-1470	ME-1670	ME-1690	ME-1890	ME-2012
Table							
Area of Table (mm)	1300 x 700	1400 x 700	1500 x 700	1800 x 700	1800 x 900	2000 x 900	2100 x 1200
Working Area (mm)	1200 x 700	1300 x 700	1400 x 700	1600 x 700	1600 x 900	1800 x 900	2000 x 1200
T-Slot (mm)	100 x 18 x 6	100 x 18 x 6	100 x 18 x 6	100 x 18 x 6	150 x 22 x 5	150 x 22 x 5	150 x 22 x 7
Work Table Max Weight (kgs)	1200	1300	1500	1600	2000	2000	2000
Travel							
X/Y/Z - Axis Travel (mm)	1200/720/700	1300/720/700	1400/720/700	1600/720/700	1600/900/800	1800/900/800	2000/1200/860
Spindle Nose to Table surface (mm)	150-850	150-850	150-850	150-850	150-950	150-950	150-1010
X/Y/Z-Guideway Type	Linear Gindeway	Linear Gindeway	Linear Gindeway	Linear Gindeway	Linear Gindeway	Linear Gindeway	Linear Gindeway
Spindle							
Spindle Taper	BT40/BT50	BT40/BT50	BT40/BT50	BT40/BT50	BT50	BT50	BT50/HSK63
Spindle rpm	10000/6000	10000/6000	10000/6000	10000/6000	6000	6000	8000/12000/18000
Transmission Method							
Spindle Motor (kw)-Fanuc	11/15	11/15	11/15	11/15	15/18.5	15/18.5	15/18.5
Spindle Motor (kw)-Mitsubishi	7.5/11	11/15	11/15	11/15	11/15	11/15	11/15
Spindle Motor (kw)-Siemens	9	15	15	15	15	15	15
Spindle Motor (kw)-Heidenhain	15	15	15	15	15	15	15
Three-Axis Motor							
X/Y/Z-Axis Servo Motor (kw)-Fanuc	3.0/3.0/3.0BS	3.0/3.0/3.0BS	3.0/3.0/3.0BS	3.0/3.0/3.0BS	3.0/3.0/3.0BS	3.0/3.0/3.0BS	3.0/3.0/3.0BS
X/Y/Z-Axis Servo Motor (kw)-Mitsubishi	3.0/3.0/3.0BS	4.5/4.5/4.5BS	4.5/4.5/4.5BS	4.5/4.5/4.5BS	4.5/4.5/4.5BS	4.5/4.5/4.5BS	4.5/4.5/4.5BS
X/Y/Z-Axis Servo Motor (kw)-Siemens	3.55/3.55/5.5BS	5.5/5.5/5.5BS	5.5/5.5/5.5BS	5.5/5.5/5.5BS	5.5/5.5/5.5BS	5.5/5.5/5.5BS	5.5/5.5/5.5BS
X/Y/Z-Axis Servo Motor (kw)-Heidanhain	3.9/3.9/4.6BS	4.6/4.6/4.6BS	4.6/4.6/4.6BS	4.6/4.6/4.6BS	4.6/4.6/4.6BS	4.6/4.6/4.6BS	4.6/4.6/4.6BS
3-Axis Cutting Feed Rate (mm/min)	10000	10000	10000	10000	6000	6000	6000
3-Axis Rapid Traverse (m/min)	24/24/24	24/24/24	24/24/24	24/24/24	20/20/20	20/20/20	20/20/15
Others							
Machine Weight / Gross Weight (kgs)	6500	9000	9500	10000	15000	16000	19000
Control							
ME-Series Control	Fanuc Oi-MF/31i, Mitsubishi M80A/M80B, Siemens 828D/840D, Heidenhain TNC620/TNC640						

Options

- Tool Changer 16/20/24/30/32/40/60
- Spindle Upgrade to Direct Drive
- 10000/12000/15000rpm Spindle Upgrade Belt Type
- 12000 rpm
- Spindle Upgrade Built-in 18000/24000 rpm
- Screw Type Chip Conveyor
- Chain Type Chip Conveyor
- Chip Wash System
- Tool measuring system
- Tool breakage system
- Linear Scale
- Spindle Oil Cooler
- Coolant Through Spindle
- Air Through Spindle
- Oil Mist Collector
- Fully Enclosed Casing