

DCM-2315 / 2815 / 3315 / 4015  
DCM-2320 / 2820 / 3320 / 4020  
DCM-3025 / 4025 / 5025  
DCM-5030



# DCM-Series

Hand Crafted to Every Customers  
Professional Needs.

High-Precision Double Column Machining Center

TRUE HIGH  
ACCURACY & A POWERFUL  
PERSONALITY DESIGNED  
FROM THE GROUND UP.

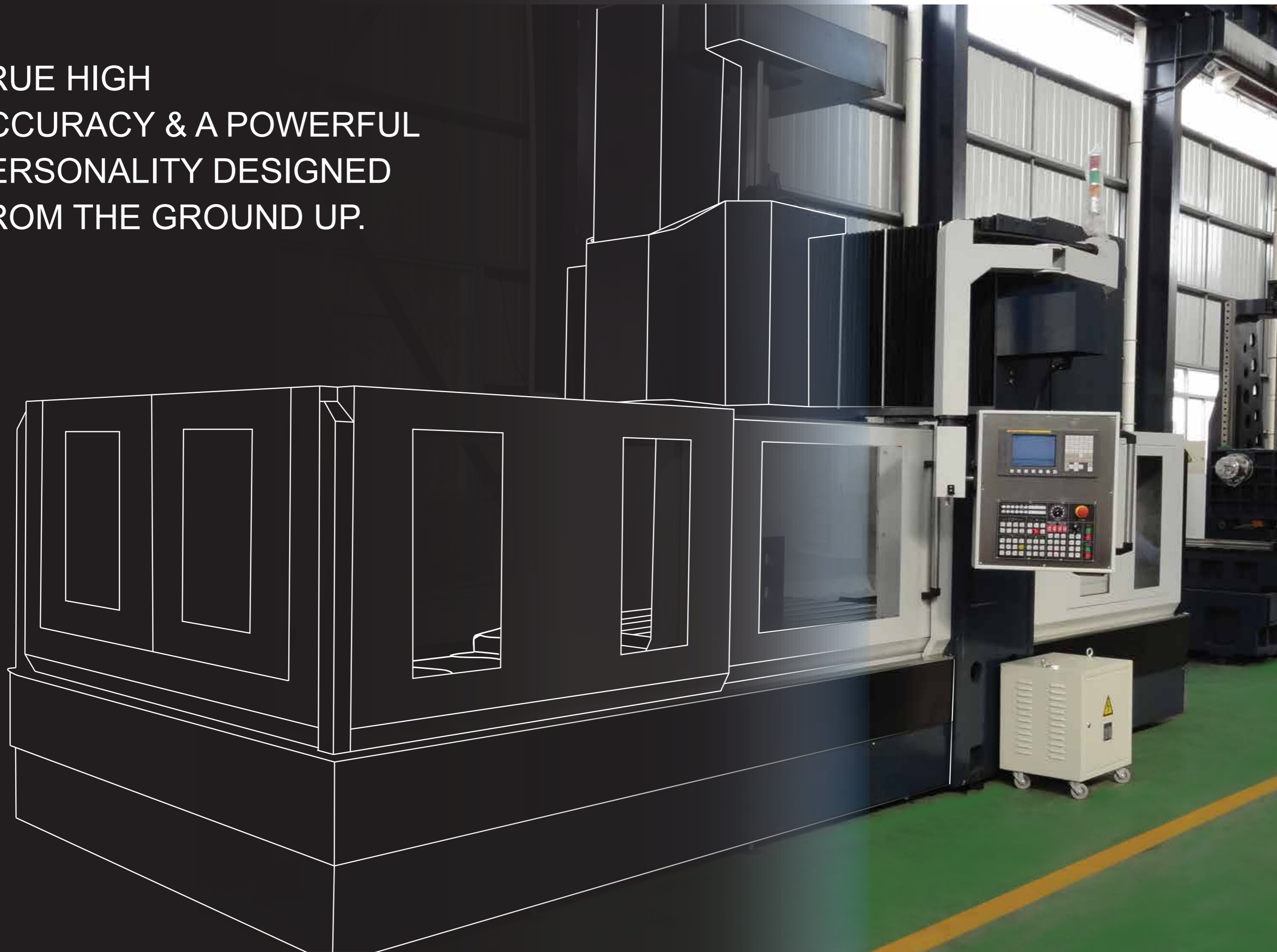

# BREAKS

## ALL RULES AND CONVENTIONS.

At the heart of the action: Thanks to its superior rigidity and dynamic machining characteristics, in the DCM Series you'll always be on top of the task at hand. The powerful design of the DCM Series machine gives the machine the high cut ability that is unmatched by many companies on the market.

The DCM Series is just as dynamic when it commands its cutting ability: With power ranging from 18.5kW to 37 kw and a maximum torque of 1000+ Nm, this machine is poised to meet any challenge. The uncompromising design and highly advanced technology also ensure that the DCM-Series is always in the lead.



1.

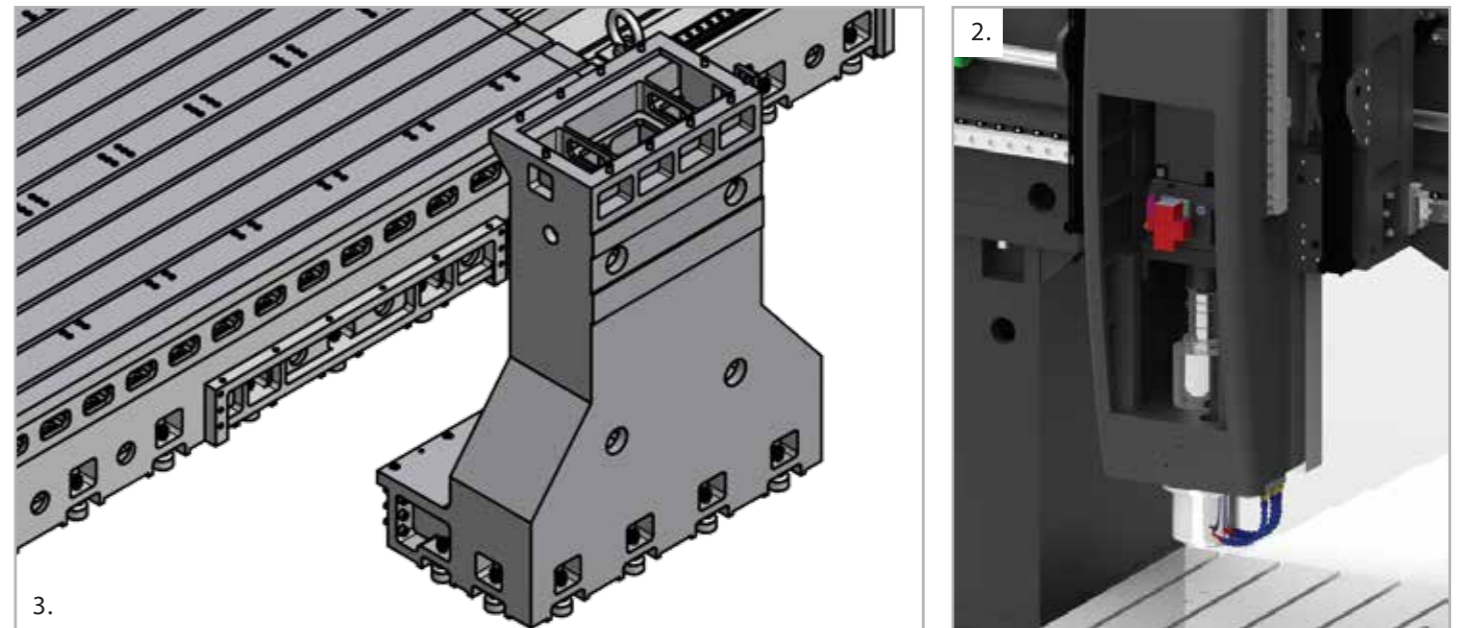

3.

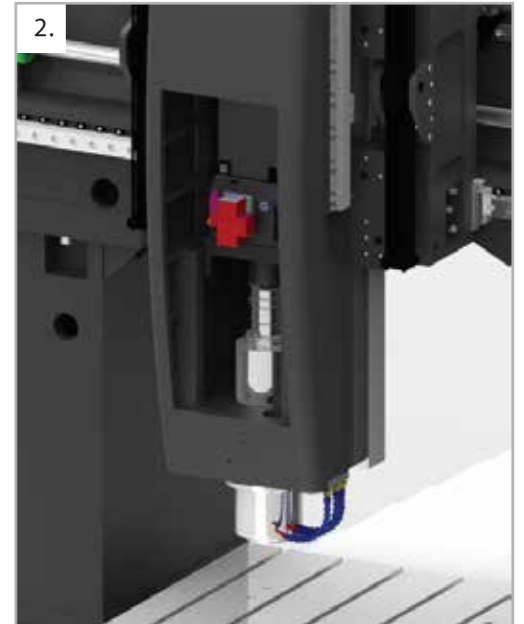

2.

1. Designed with Protection.

The DCM-Series can come with protection casing that is designed with beauty and ergonomic at the same time. With a super large sliding door, the DCM-Series can load and unload large parts easily and at the same time giving the user a fully protective casing.

2. Designed with Technology.

Unlike most bridge type machines on the market, a direct spindle on a bridge type will usually need a transmission shaft to send the power from the spindle motor to the spindle. With this design, power is lost during the transmission of power from the twist of the shaft. The dynamic design of the DCM-Series direct drive is designed to connect the spindle motor directly to the spindle without a long shaft in between. This helps minimize power lost during power transmission and at the same time increasing spindle response.

3. Designed with Rigidity.

The larger the contact surface the better the rigidity the machine will have. This is the concept the DCM-Series machine was designed with. Extremely large contact points from the base of the machine to the cross beam of the headstock gives the machine extreme rigidity under even the heaviest cutting conditions.

# DCM-SERIES FEATURES THE MAPLE DIFFERENCE

The DCM-SEREIS features\* – Machine features may not be the same for each machines. Each machine can be customized to every customer individual needs.

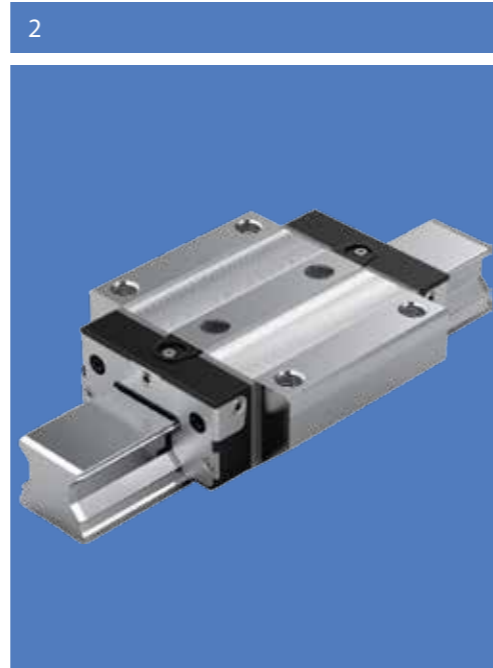

1. Spindle Equipped:  
Std: 6,000 rpm with 4 bearing  
Opt: 6,000 rpm with 6 bearing  
Opt: High Speed 12,000-18,000 rpm  
Opt: Heavy Duty Gear Box 6,000-10,000 rpm.
2. Heavy Duty Linear Motion:  
Std: Heavy duty roller type linear guideway (Grade P).  
Size range 55-65 mm.
3. High Precision Ballscrew Drive:  
Std: Heavy duty and high precision ballscrew (Grade C1-C3).  
Size range 50-100 mm.
4. High Precision Gear Driven:  
Std: Heavy duty roller type linear guideway (Grade P).  
Size range 55-65 mm.

## DCM-SERIES ATTACHMENT HEADS

### Head Types:

- Fixed - Fixed Heads
- Manual - Manual Exchange with Manual Indexing
- Semi Auto - Manual Exchange with Auto Indexing
- Fully Auto - Auto Exchange with Auto Indexing

**1. Fixed 5 Face Milling Head**  
Auto Indexing at 5/2.5/1° degree angle.



**2. 90 Degree Milling Head**  
It comes in three types:  
Manual / Semi / Full Auto at 5/2.5/1° Degree Indexing



**3. Universal Milling Head**  
It comes in three types:  
Fixed / Manual / Semi / Full Auto at 5/2.5/1° Degree Indexing.



**4. Two Axis / C-Axis Milling Head**  
It comes in four types:  
Fixed / Manual / Semi / Full Auto at 5/2.5° Degree Indexing

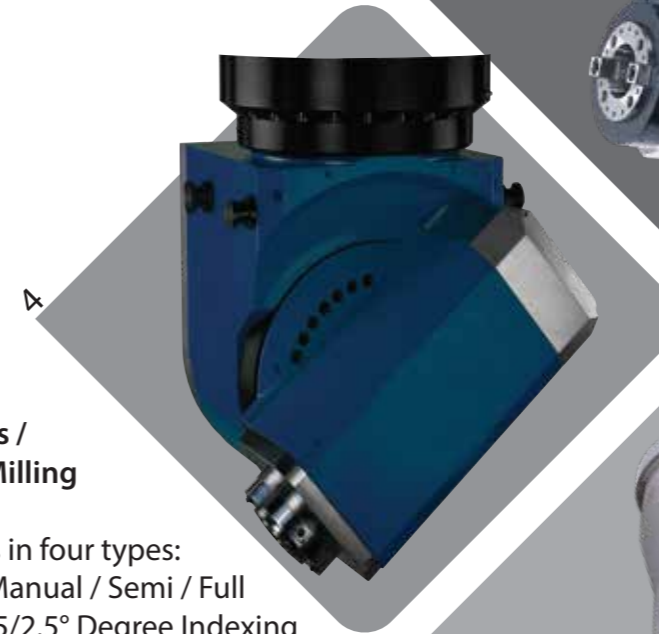

**5. Extend Milling Head**  
It comes in two types:  
Manual / Full Auto with 200 / 400 mm extension.



\*Also comes in two axis continues.



# MACHINE SPECIFICATIONS DCM-SERIES

Specification	DCM-2315	DCM-2815	DCM-3315	DCM-4015	DCM-2320	DCM-2820	DCM-3320	DCM-4020	DCM-3025	DCM-4025	DCM-5025	DCM-5030	
<b>Travel</b>													
X-Axis Travel	mm	2300	2800	3300	4000	2300	2800	3300	4000	3000	4000	5000	5000
Y-Axis Travel	mm	1500	1500	1500	1500	2000	2000	2000	2000	2700	2700	2700	3000
Z-Axis Travel	mm	860	860	860	860	860	860	860	860	1000	1000	1000	1000
Door Width	mm	1500	1500	1500	1500	2000	2000	2000	2000	2700	2700	2700	3000
Spindle Nose To Worktable	mm	150-1010	150-1010	150-1010	150-1010	150-1010	150-1010	150-1010	150-1010	150-1150	150-1150	150-1150	150-1150
<b>Worktable</b>													
Worktable Size	mm	2300 x 1200	2800 x 1200	3300 x 1200	4000 x 1200	2300 x 1700	2800 x 1700	3300 x 1700	4000 x 1700	3200 x 2250	4200 x 2250	5200 x 2250	5200x2800
T-Slot	mm	190 x 22 x 6	190 x 22x 6	190 x 28 x 6	190 x 28 x 6	190 x 22 x 8	190 x 22 x 8	190 x 28 x 8	190 x 28 x 8	200 x 28 x 11	200 x28 x11	200 x28 x11	200x28x13
Working Range	mm	2300 x1500	2800x1500	3300x1500	4000x1500	2300x2000	2800x2000	3300x2000	4000x2000	3000x2500	4000x2700	5000 x 2700	5000x3000
<b>Spindle</b>													
Spindle Taper		BT50	BT50	BT50	BT50	BT50	BT50	BT50	BT50	BT50	BT50	BT50	BT50
Spindle Speed (Std. Belt)	rpm	6000	6000	6000	6000	6000	6000	6000	6000	6000	6000	6000	6000
Spindle Speed (Op. Gear)	rpm	6000	6000	6000	6000	6000	6000	6000	6000	6000	6000	6000	6000
Spindle Motor (Fanuc)	kw	15-18.5	15-18.5	22-26	22-26	15-18.5	15-18.5	22-26	22-26	22-26	22-26	22-26	22-26
Spindle Drive Type		Belt	Belt	Belt	Belt	Belt	Belt	Belt	Belt	Belt	Belt	Belt	Belt
Three-Axis Drive Type		Direct Drive X, Y, Z	Direct Drive X, Y, Z	Direct Drive X, Y, Z	Direct Drive X, Y, Z	Direct Drive X, Y, Z	Direct Drive X, Y, Z	Direct Drive X, Y, Z	Direct Drive X, Y, Z	Direct Drive X, Y, Z	Direct Drive X, Y, Z	Direct Drive X, Y, Z	Direct Drive X, Y, Z
Three-Axis (Mitsubishi)	kw	4.5/4.5/4.5	4.5/4.5/4.5	7/4.5/4.5	7/7/7	4.5/4.5/4.5	4.5/4.5/4.5	7/4.5/4.5	7/7/7	7/7/7	9/7/7	9/7/7	9/7/7
Three-Axis (Fanuc)	kw	3/3/3	3/3/3	6/7/7	6/7/7	3/3/3	3/3/3	6/7/7	6/7/7	6/7/7	6/7/7	9/7/7	9/7/7
<b>Feedrate</b>													
Cutting Feedrate	M/Min	10-6000	10-6000	10-6000	10-6000	10-6000	10-6000	10-6000	10-6000	10-6000	10-6000	10-6000	10-6000
Rapid Feedrate X/Y/Z	M/Min	20/20/12	20/20/12	12/20/12	12/20/12	20/20/12	12/20/12	12/20/12	12/20/12	12/12/12	10/12/12	10/12/12	10/12/12
<b>Accuracy</b>													
Positioning-(JIS 6338) (±)	mm	0.015	0.015	0.020	0.020	0.015	0.015	0.020	0.020	0.025	0.025	0.025	0.025
Repeatability-(JIS6338) (±)	mm	0.005	0.005	0.008	0.008	0.005	0.005	0.008	0.008	0.015	0.015	0.015	0.015
<b>Tool Changer</b>													
Type of Tool Shank		BT50	BT50	BT50	BT50	BT50	BT50	BT50	BT50	BT50	BT50	BT50	BT50
Tool Storage Capacity		24(30/32/40)	24(30/32/40)	24(30/32/40)	24(30/32/40)	24(30/32/40)	24(30/32/40)	24(30/32/40)	24(30/32/40)	24(30/32/40)	24(30/32/40)	24(30/32/40)	24(30/32/40)
Max. Tool Diameter	mm	Φ110	Φ110	Φ110	Φ110	Φ110	Φ110	Φ110	Φ110	Φ110	Φ110	Φ110	Φ110
Max. Tool Diameter w/o Adj Tools	mm	Φ200	Φ200	Φ200	Φ200	Φ200	Φ200	Φ200	Φ200	Φ200	Φ200	Φ200	Φ200
Max. Tool Length	mm	350	350	350	350	350	350	350	350	350	350	350	350
Max. Tool Weight	Kgs	15	15	15	15	15	15	15	15	15	15	15	15
<b>Others</b>													
Three-Axis guideway		Linear/Linear /Box	Linear/Linear /Box	Linear/Linear /Box	Linear/Linear /Box	Linear/Linear /Box	Linear/Linear /Box	Linear/Linear /Box	Linear/Linear /Box	Linear/Linear /Box	Linear/Linear /Box	Linear/Linear /Box	Linear/Linear /Box
Air Required	Kg	6.5	6.5	6.5	6.5	6.5	6.5	6.5	6.5	6.5	6.5	6.5	6.5
Power Required	KVA	45	45	45	45	45	45	45	45	45	45	60	60
Coolant	HP	3/4	3/4	3/4	3/4	3/4	3/4	3/4	3/4	3/4	3/4	3/4	3/4
Max Weight On Table	T	6.3	6.3	7.0	7.6	6.3	6.7	7.3	7.9	10	13	16	17
Machine Weight	T	19	22	24	27	20	23	25	28	42	44	50	53

## Standard Accessories

- ◆ Mitsubishi / Fanuc / Siemens / Heidenhain
- ◆ Spindle Oil Cooler
- ◆ Automatic Lubricating System
- ◆ Twin Screw and Chain Type Chip Conveyor
- ◆ Heat Exchanger for Electric Cabinet
- ◆ Twin Hydraulic Counter Weight Cylinders
- ◆ X/Y/Z-Axis Telescoping Cover
- ◆ Splash Guard
- ◆ Cutting Coolant System
- ◆ Cutting Air System
- ◆ LED Work Light
- ◆ Ladder for Maintenance
- ◆ Maintenance and Operational Manual
- ◆ Air Gun
- ◆ Transformer
- ◆ Rigid Tapping
- ◆ RS232 Transmission Line
- ◆ External Hand Wheel
- ◆ Complete Telescoping Covers
- ◆ Auto Power off System
- ◆ Tool Box & Files With Machine
- ◆ Foundation Leveling Bolts And Leveling Blocks

## Optional Accessories

- ◆ ATC (24, 32,40, 60, 90, 120 tools)
- ◆ Spindle 8000 / 10000 rpm (Belt-Drive)
- ◆ Spindle 6000/8000/10000/12000 rpm (Gear Box)
- ◆ Spindle 8000/10000/12000/15000 rpm (Direct Drive)
- ◆ Spindle 12000/15000/18000/24,000 /30,000 rpm (Built-in)
- ◆ Auto Tool Length Measurement
- ◆ Auto Parts Probe Measuring System
- ◆ CTS System (20/30/50/70 Bar)
- ◆ Coolant Auto Air Mist Device
- ◆ Linear Scales (Heidenhain / Fagor)
- ◆ 90 degree head
- ◆ Universal Head
- ◆ Two-Axis Heads
- ◆ Extended Head
- ◆ Rotary Table
- ◆ Fully Enclosed Casing