

TA26.P



caratteristiche/features



peso/weight



rotazione/rotation



prestazioni/performance

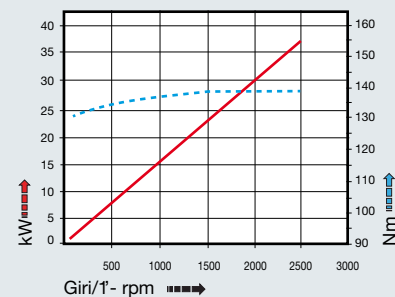

tipi mandrino disponibili / available spindle types

- 2** Albero portafrese
Milling shaft
Ø16-Ø27-Ø32
- 3** Weldon
Whistle-Notch
Ø32
- 4** DIN69893-HSK
HSK63
- 5** COROMANT
CAPTO®
C4
- 6** ABS
Licenza KOMET®
ABS50

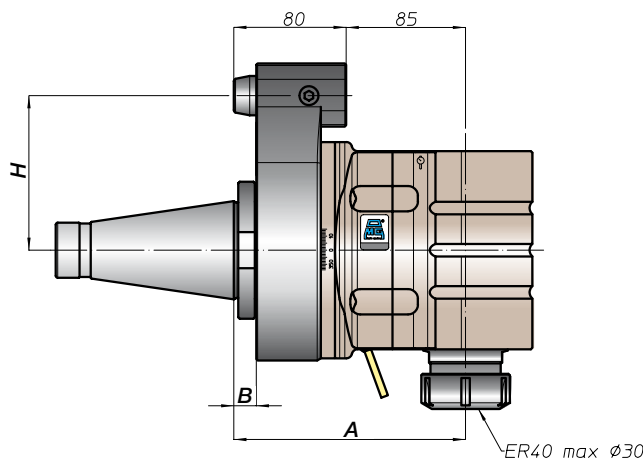
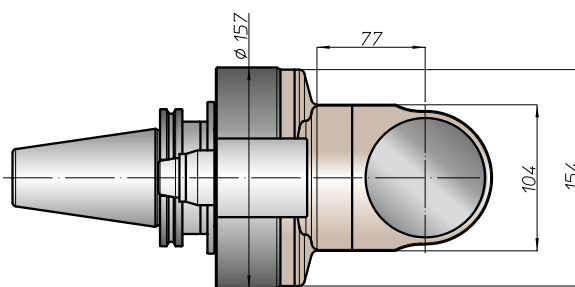
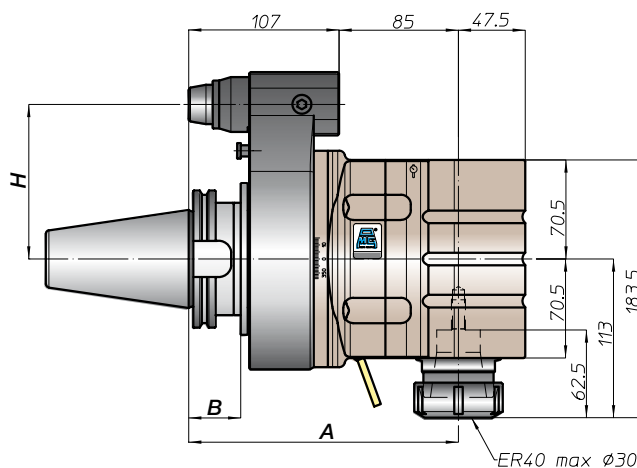
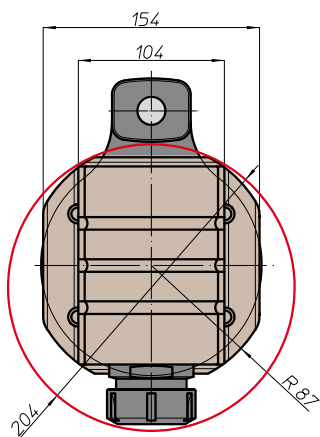

CONO SHANK	size	H			
		A	B	standard	optional
DIN69871 *	-	-	-	-	-
DIN69871 *	45	-	-	110	-
DIN69871 *	50	192	35	-	-
ANSIB5.50 *	-	-	-	-	-
ANSIB5.50 *	50	-	-	110	-
BT *	-	-	-	-	-
BT *	50	200	45	110	-
HSK	-	-	-	-	-
DIN69893	80	201	46	110	-
DIN69893	100	-	-	-	-
CAPTO	-	-	-	-	-
ISO28623	-	196	-	-	-
ISO28623	C8	-	-	110	-
KM	-	-	-	-	-
KM	-	192	-	-	-
KM	100	-	-	110	-
DIN2080	-	-	-	-	-
DIN2080	-	165	16	110	-
DIN2080	50	-	-	-	-
NMTB	-	-	-	-	-
ANSIB5.18	50	165	16	110	-

* Option: Dual Contact

