

TAPMATIC

TAPMATIC TAP WRITER

Safety and Operation Instruction



MARK IT WHILE YOU MAKE IT!

At High Speed **Without** Second Operations

TAPMATIC

TIC AG • Alte Rheinstrasse 29 • CH-9451 Kriessern
☎ +41 (71) 757 59 00 • 📠 +41 (71) 757 59 01 • 🌐 www.tapmatic.ch

VÄLV
Membrantechnik

1 von 16

Tapmatic TapWriter® Operating Instructions and Set-up Guide

Version 7/29/09

1. TapWriter All-in One Overview

The TapWriter at a glance

Advantages, Function and Characteristics of the TapWriter.

The Tapmatic TapWriter Marking Head was designed as a simple to use, conomical, spindle actuated permanent marking device for a wide variety of materials from hardened tool steel to delicate plastics. Since the device does not rely on electrical or compressed air input or any similar interfacing, it is easily integrated into vertical or horizontal machining centers, milling machines and similar CNC machines with rotating spindle, similar to integrating a tapping head or angle head. The TapWriter marking head can be manually mounted in the machine spindle, or it may be placed in the machine's ATC (automatic tool changer) and automatically loaded into the spindle.

The TapWriter Marking Head is a very cost-effective, smart alternative to costly dot-peen marking machines, vibrating stylus heads or pin marking machines, or alternative marking methods including chemical etching, die or roll stamping, laser markers and messy ink printers.



The machining envelope of the machine tool the TapWriter is used on, is the only limit of the size and area to be marked. The “marking window” is therefore far larger than on virtually any dot-peen or other marking machine available. Parts that are machined on a machining center can be marked in location and do not have to be moved, located and re-fixtured on a separate marking machine, saving costly handling and processing time and preventing errors. Multiple parts on a tombstone or index fixture, or in gang fixtures or multiple vises can be marked in location in one marking cycle.

The TapWriter has a number of important advantages and characteristics over other conventional marking methods. The TapWriter is a spindle-actuated mechanical Dot-Peen Marker, which cold-forms a series of discrete or connected dots with precise, low stress marking force. The device accurately and indelibly marks alpha-numeric text, symbols, dates and serial numbers, batch codes, logos and graphics. Various fonts and character sizes can be marked in straight-line, angled, arced, circular, mirrored or reflected text. The carbide stylus can easily mark in a wide variety of materials: it clearly marks cast iron or steel as hard as 55 HRC or dense material like heavy metal, but just as easily marks softer materials like aerospace alloys, aluminum, other non-ferrous metals, and delicate plastics.

TAPMATIC

Operational machine integration is also simple. Most general purpose Machining Centers or Milling Machines now are equipped with CNC controls with engraving software; this makes the use of the TapWriter Marking Head very straightforward. Older machines, which have no engraving feature, can be equipped with commercially available, low-cost engraving software, or a PC-generated marking program may be downloaded for execution by the machine control. Marking capabilities of the TapWriter head depend only on the capabilities of the machine's engraving or CAD software used. The dot-peen marks produced by the TapWriter head are an easily readable, permanent inscription for product identification or traceability marking options.

The TapWriter head provides a very affordable and cost-effective solution for permanent parts identification in a wide range of manufacturing industries. The TapWriter functions by actuating a tungsten carbide stylus with controlled radius tip. The top of the stylus is struck by the actuating hammer and "thrown" inside a nose cone downward with velocity toward the marking surface. Near the end of the stroke movement, the stylus tip penetrates the surface to be marked. The tip of the stylus creates a controlled indentation ("Dot"). A stylus return spring under the stylus cap returns the stylus back up to the starting position. The depth of the indentation depends on the velocity of the stylus and on the resistance (hardness and density) of the work-piece material to be marked. Slight work piece surface height variations do not change the marking depth, an important feature when marking castings, forgings, curved surfaces or the like. Changing the rotational speed of the machine spindle can vary the marking depth. Slower rotational speed will decrease the velocity of the marking stylus and result in less marking depth, increasing the rotational speed will generally result in a deeper mark. Varying the marking plane distance from the marking surface can also have some effect on the penetration of the stylus but to a lesser degree than changes in the rotational speed.

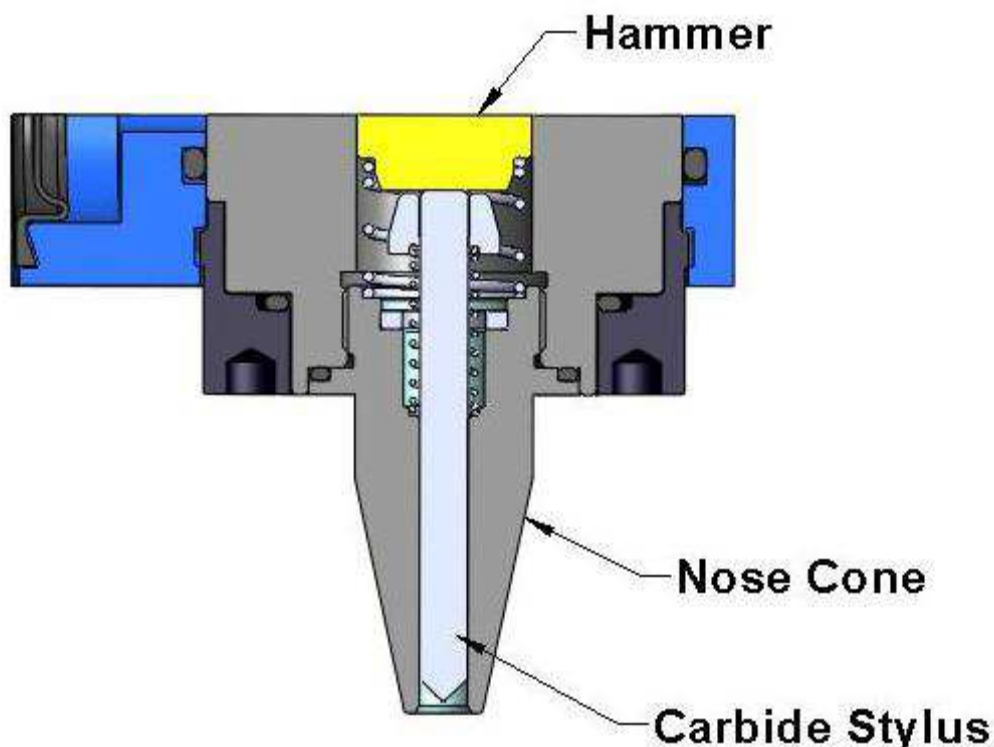

2. Set-up Guide:

Set-up and Installation Instructions on Machine Tool

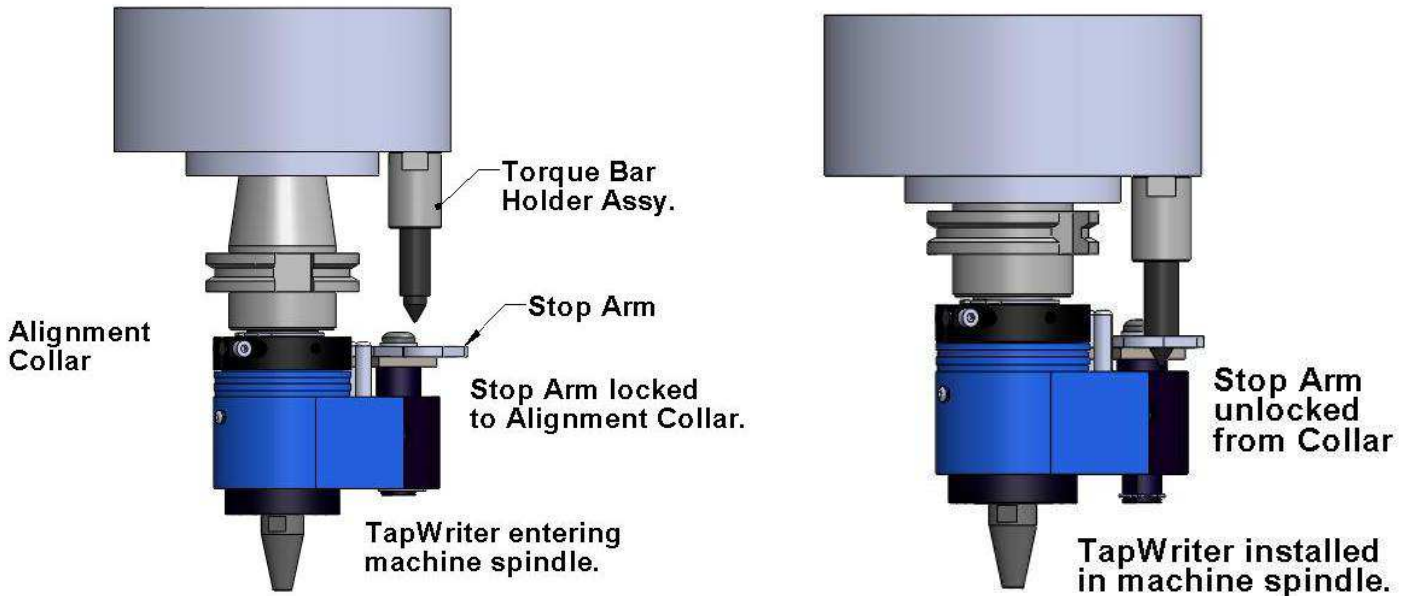

In order for the TapWriter to operate, a stop arm is used to prevent the housing from rotating. To allow the tool to travel through an automatic tool change and the stop arm to find the stop location next to your machine spindle, the alignment collar locks the stop arm in a specific orientation. This alignment collar can be adjusted so that its slot is in any position relative to the NC shank. When the tool is out of the machine spindle, the stop arm is engaged in the slot in the alignment collar. This then keeps the stop arm locked in its orientation position. When the tool is placed in the machine spindle by the tool changer, the stop location next to the machine spindle engages the stop arm preventing it from turning and at the same time pushes it down against a spring so that the stop arm is unlocked from the alignment collar. This is the position for operation. When the marking operation is completed the machine spindle orients to the tool change position bringing the slot in the alignment collar back in to position to accept the stop arm as the tool is removed from the machine spindle by the tool changer.



The following steps involve loading and unloading by hand. Do not attempt to make an automatic tool change until all steps are completed and clearance has been confirmed.

Never attempt an installation without first reading all safety instructions for this tool and your machine. Please see Page 11.

Automatic tool changes should only be made on enclosed machines.

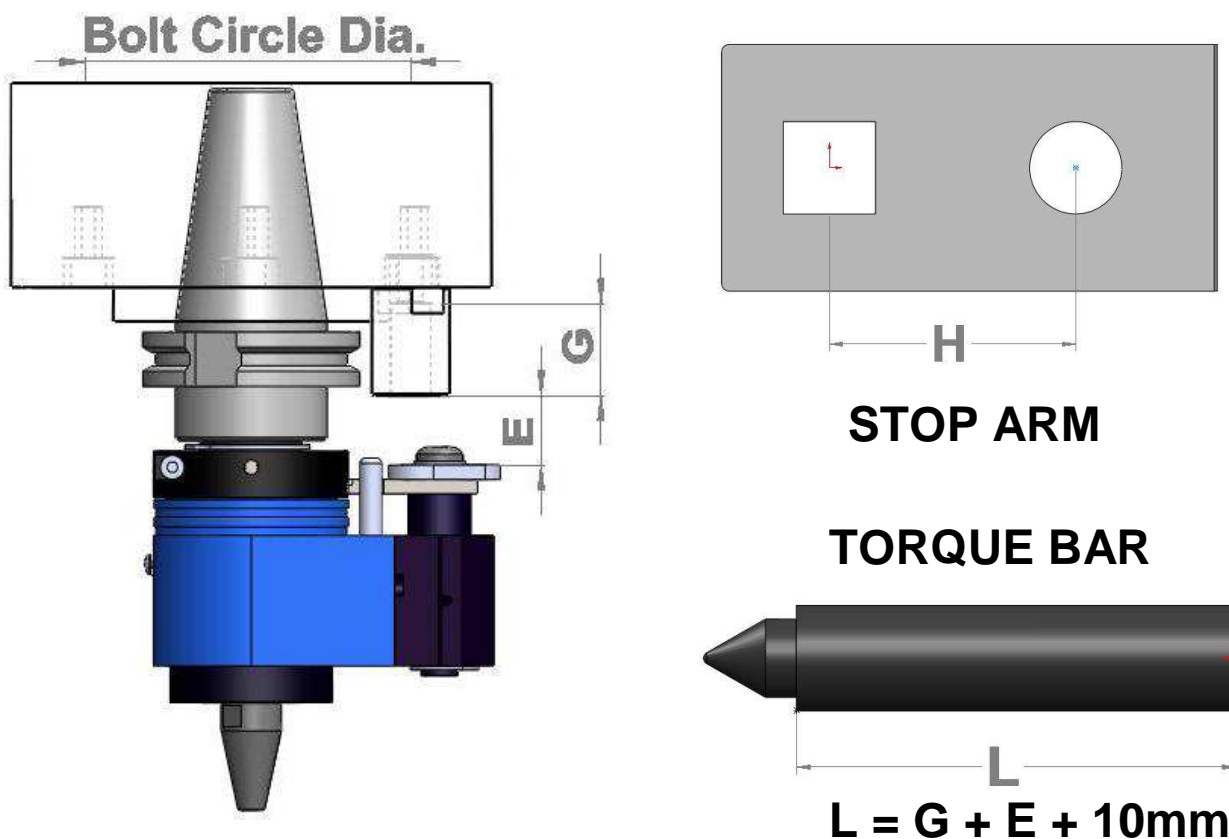

Modifying or selecting the Stop Arm: The TapWriter comes with a blank stop arm that can be modified to fit the bolt circle of your machine. First determine the bolt circle diameter shown in the figure above. If you would like to order a ready made stop arm please let us know the bolt circle diameter and we can supply the stop arm to fit your machine. If you would like to modify the blank stop arm enclosed you will need to drill a 10mm hole at “H” as given by the following formula.

$$H = \frac{\text{Bolt Circle Diameter}}{2} - 55\text{mm}$$

Cutting Torque Bar to Length: Please let us know the size of the thread of the bolt you wish to use for mounting the anti-rotation bar and we can supply a ready-made bar for your machine. The length for the bar is then given by the formula shown in the figure above. The torque bar must be long enough to push the stop arm down to unlock from the alignment collar but not so long that it bottoms out against the top of the housing.

Important: Be sure to adjust alignment collar according to the instructions on page 7.

Stop Block Alternative Installation

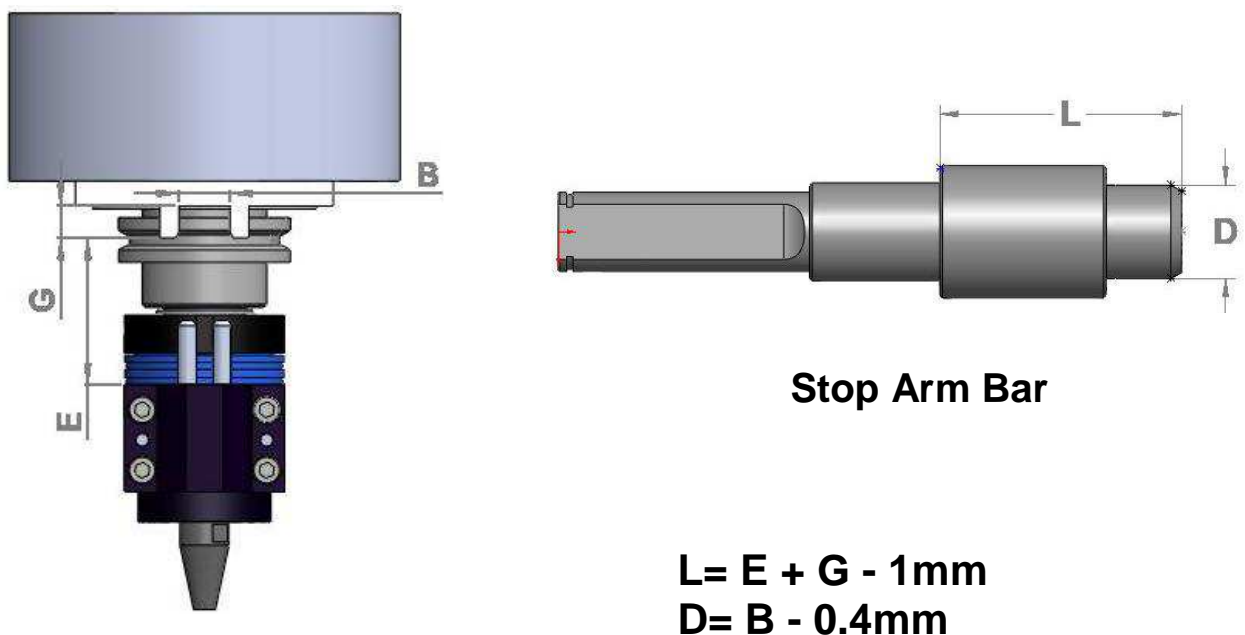
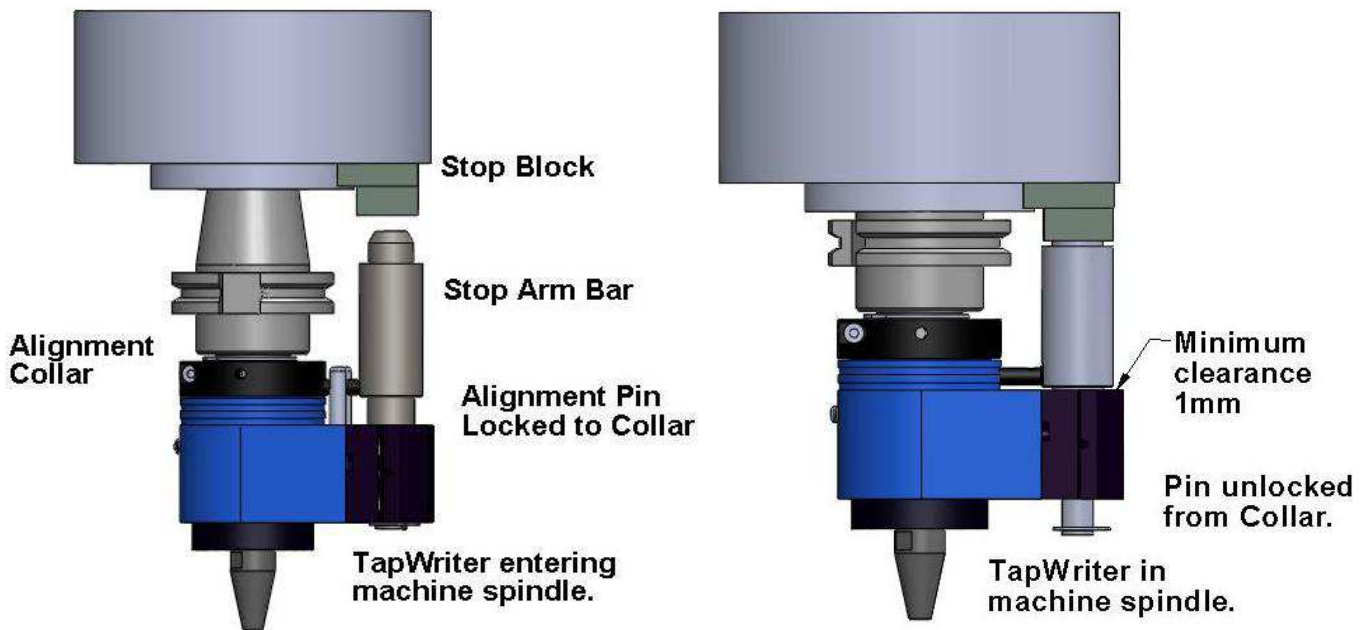

You may also use the alternative installation shown above using a stop block. Please let us know whether the distance from the centerline of your machine is 55mm, 65mm, or 80mm and we can supply the correct assembly for your machine.

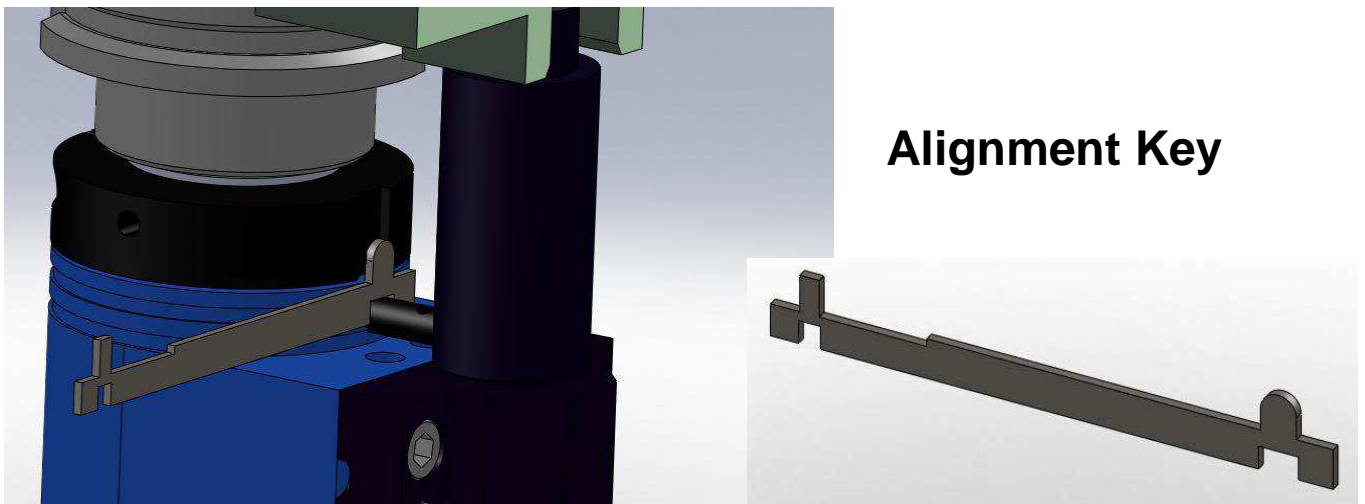

Adjustment of the Alignment Collar: With the TapWriter in the machine spindle and the stop arm engaged with the stop location next to your machine spindle, **orient the machine spindle to the tool change position**. Bring the slot in the alignment collar in line with the tab of the stop arm. There is a small alignment key included with the tool to help you to line this up. **Tighten the collar's clamping bolt very securely.**

With the collar set and after checking for any possible clearance problems with the tool changer or in the storage area make several automatic tool changes.

Set-up on work piece and Programming

Clearance Plane, Marking Plane, RPM, feed rate (X & Y-Axis) and down feed (Z-axis). With the tool loaded in the machine spindle and the spindle rotating, the pointed tip of the marking stylus (# 73402A) protrudes slightly below the lower end of the nose cone (# 73449) when the stylus is fully extended at each marking stroke. Therefore the tool needs to be programmed / positioned so there is clearance between the lower end of the nosepiece guide and the flat marking surface; this clearance is known as the Marking Plane clearance. The position of the lower end of the nosepiece is known as the Marking Plane. After marking each character or line, the tool needs to lift off the marking surface, so no dots are marked as the machine moves the tool in X- or Y-axis direction to the start of the next letter or line to be marked. The plane the tool is programmed to lift off to is known as the Clearance Plane. The lift off in Z-axis must be programmed to be fast, either in rapid mode or at a very fast feed rate (see Table # 101 for Recommended Operating Parameters). Likewise the down movement in the Z-axis should be made at the same fast speed. This is very important in order to avoid double hits of the stylus at the start and end of a character or line; it also reduces marking time substantially. Up to 75% time reduction over standard engraving with solid engraving tools has been reported.



TAPMATIC

A safe starting point for marking steel (for example AISI 4130 at 30 HRC hardness) with 1/4" (6 mm) high characters is as follows: 750 RPM spindle speed, 50 in/min (1270mm/min) feed rate (X +Y axis), Rapid speed or 400 in/min (10,000mm/min) lift-off and down-feed (Z-axis), 0.250" (6mm) Clearance Plane, 0.070" (2mm) Marking Plane. Below are some recommended programming parameters.

Marking Plane:	1.5mm (0.06")	Minimum
	3mm (0.12")	Maximum

The Marking Plane has an influence on the depth of dot penetration. The closer to the work piece the greater the penetration. A good distance for most applications is 2mm. **IMPORTANT:** Do not set Marking Plane closer than 1.5mm as this could cause excessive wear to internal components.

Speed:	750 RPM	Minimum
	1000 RPM	Maximum

The speed is a very important factor and has a big influence on the resulting mark. Higher RPM means more dots at a given feed rate. Speed also has a strong influence on the depth of the penetration because the higher the rotational speed the greater the velocity of the carbide stylus when thrown against the work piece.

Clearance Plane:	6mm (0.25")
-------------------------	--------------------

A clearance plane of 6mm is safe to insure that the carbide stylus can not touch the work piece when moving between characters.

Z axis Moves:	Use rapid or fast feed rate.
	For example 13000 mm/min or 500 in/min.

By using a fast movement between clearance plane and marking plane the possibility of extra dots at these points is minimized.

Marking Feed Rate:	250 mm/min (10 in/min)
	2500 mm/min (100 in/min)

There really are no limits on the feed rates you can program, but the reality is that at some point the machine can not react fast enough to achieve an improvement in cycle time for the short distances moved when drawing small characters. At a given RPM a faster feed rate results in a greater distance between the dots. At a slower feed rate dots run together to produce marks that appear more like a continuous line. Following is a theoretical formula for distance between dots.

Distance Between Dots = Feed Rate / (2 X RPM)

Look Ahead, Exact Stop, Acceleration-Deceleration Ramping

The “look-ahead” function is important to the speed and quality of marking. Newer CNC machine tools with modern CNC controls will achieve better, cleaner marks with equally spaced dots at higher speeds than older machine tools with older model controls. The difference is similar to milling results achieved with the two options. A modern machine and control with “look-ahead” function will produce characters and marks with sharper corners and equally spaced dots; older machines and controls, especially in noramp mode, may produce characters with somewhat rounded corners, particularly at higher RPM and feed rates. If the same program is run in Exact mode (with ramping) the corners will be sharper, but due to the slow-down in the corners of letters and characters at a high programmed feed rate, the dots will be placed closer due to the slow-down. The slow-down in Exact mode will also add extra time to the marking process. We recommend some test marking on your own machine to find the right parameters fitting your machine, control and desired marking quality.



With Exact Stop or Ramping.

Without Exact Stop.

The Marking Process, Examples and some Recommended Operating Parameters

Table 101 below gives some examples of suggested Marking Plane, RPM and Feed Rate for different applications. These are meant only as examples. We suggest you program a test run using suggested parameters for a similar application to yours, and then adjust the parameters if necessary to achieve the desired marking depth, cycle time, and quality.

Table 101 Suggested Operating Parameters

Material Character	Size	Marking Plane	Clearance Plane	Revolutions Per Minute	Feed Rate
6061 Alum	2mm	2.5mm	6mm	750 RPM	250 mm/min
6061 Alum	3mm	2.5mm	6mm	750 RPM	1000 mm/min
6061 Alum	6mm	2mm	6mm	850 RPM	1000 mm/min
4140 HRC 30	6mm	2mm	6mm	1000 RPM	1270 mm/min
S7 HRC 55	6mm	2mm	6mm	1000 RPM	1270 mm/min

Examples in Aluminum

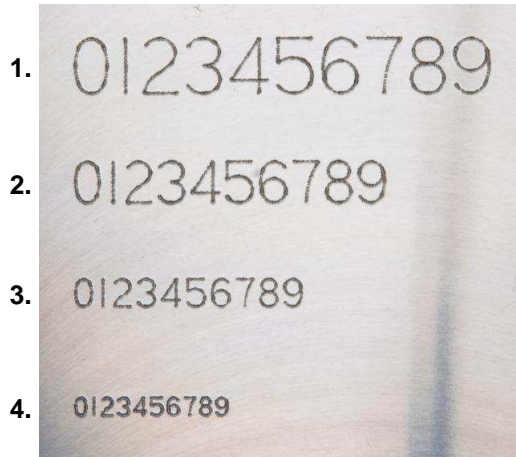

1. Character height 6mm, marking plane 2.5mm, 850 RPM, feed rate 500 mm/min.
2. Character height 5mm, marking plane 2.5mm, 850 RPM, feed rate 500 mm/min.
3. Character height 3mm, marking plane 2.5mm, 750 RPM, feed rate 250 mm/min.
4. Character height 2mm, marking plane 2.5mm, 750 RPM, feed rate 250 mm/min.

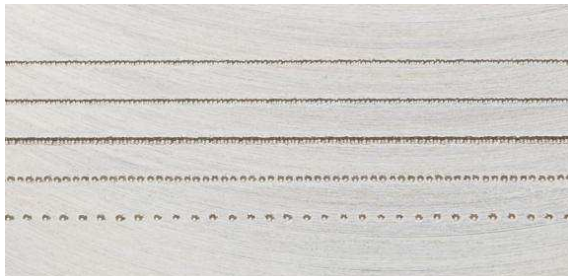

Marking plane 3mm, 850 RPM,
500 mm/min.

3. Safety

Safety Precautions and Instructions



To avoid serious injury and ensure best results for your application, please read carefully *all* operation and safety instructions for your TapWriter marking head, as well as all other safety instructions that are applicable, especially those for your machine tool.

Proper Clothing: The rotating spindle of a machine can snag loose fitting clothing, jewelry, or long hair. Never wear jewelry, long sleeves, neckties, gloves or anything else that could become caught when operating a machine tool. Long hair must be restrained or netted to prevent it from becoming entangled in rotating spindle. Steel-toed boots should also be worn in any machine environment.

Proper Eye Protection: Always wear safety glasses with side shields to protect your eyes from flying particles.



Proper Work Piece Fixturing: Never hold the work piece or the vise it is held in by hand. The work piece must be clamped firmly to the table of the machine so that it cannot move, rotate or lift.

On machining Centers: Automatic tool changes should only be made on enclosed machines.

The TapWriter can become hot to the touch after operation. Use caution when removing from the machine or handling.

Always be aware of the Potential Hazards of a Machining Operation: Sometimes working with your machine can seem routine. You may find that you are no longer concentrating on the operation. A feeling of false security can lead to serious injury. Always be alert to the dangers of the machines with which you work. Always keep hands, body parts, clothing, jewelry, and hair out of the areas of operation, when the machine spindle is rotating. Areas of operation include the immediate point of machining and all transmission components including the TapWriter. Never bring your hand, other body parts or anything attached to your body into any of these areas until the machine spindle is completely stopped.

Be aware of any other applicable safety instructions or requirements.

4. Maintenance

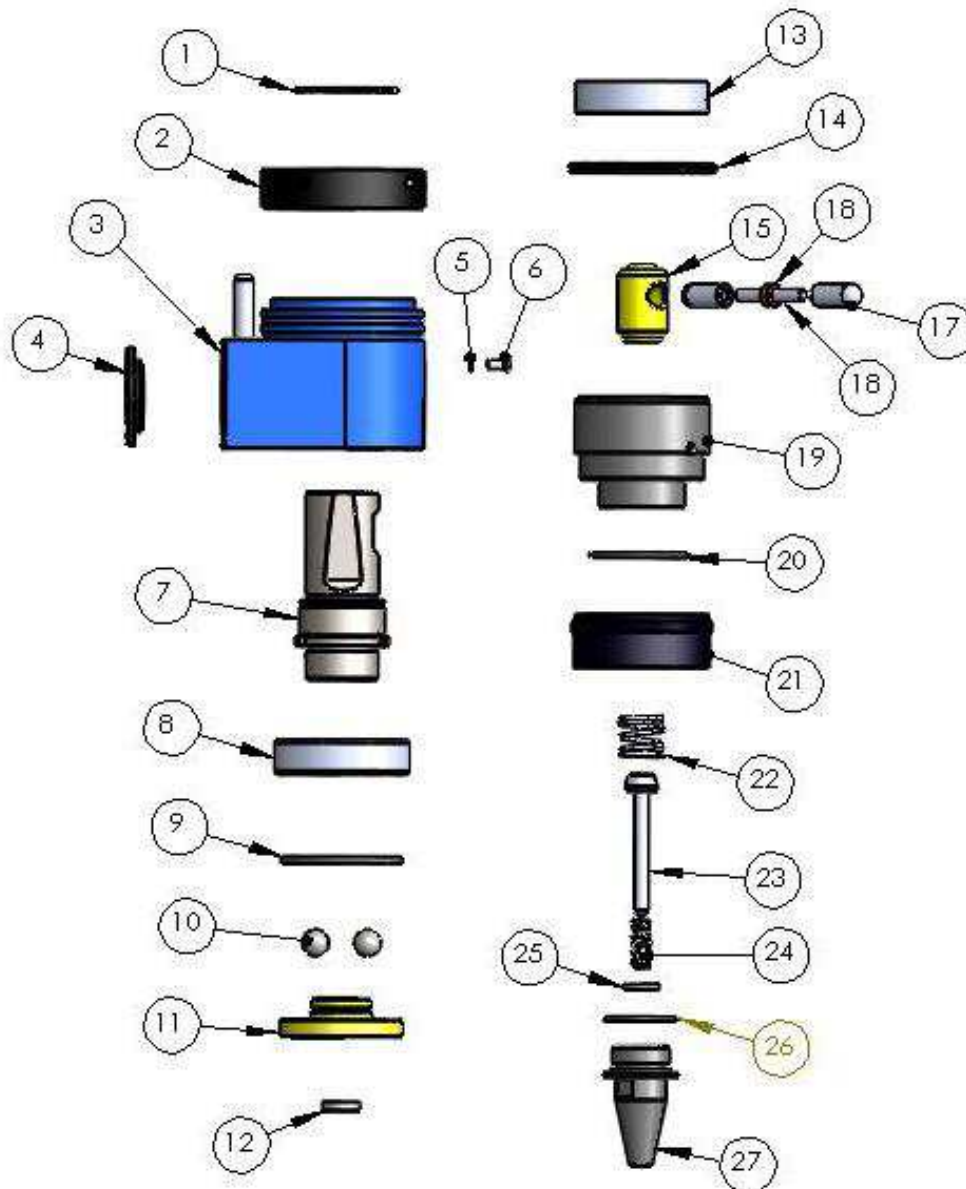

Changing Stylus and Springs: You can easily replace the stylus, stylus spring or hammer spring by simply unthreading the Nose Cone 27 from the bottom of the housing. Be sure not to lose O-Ring 26, during this procedure.

Protection Against Corrosion and Lubrication: To protect your TapWriter from corrosion we recommend spraying the inside and outside of the tool with Prolong SPL100 (www.prolongsales). To lubricate the inside of the tool spray through the housing's grease hole and also spray inside bottom of housing when nose cone is removed. **Please note it is not necessary to run coolant on the TapWriter or Work Piece during the marking operation.**

TapWriter Parts List

ID Nr.	Bestell-Nr.	Description
1	71218E	Collar Truarc Ring
2	72160A	Alignment Collar
3	72101B	Housing
4	71754	Diaphragm
5	712651	Grease Hole Washer
6	73462	Grease Hole Screw
7	712191	1" Mount
7	7121931	25mm Mount
8	60308	Housing Bearing
9	73435	Ball Plate
10	62875	9mm Balls (2 required)
11	73405	Threaded Driver
12	73427	Hammer Dampener
13	71238	Spacer
14	712501	Housing O-Ring
15	73414	Hammer
16	734071	Axle Washer
17	73432	Roller Pins (2 required)
18	73407	Axle
19	73413	Hammer Guide
20	71244	Lock Nut O-Ring
21	73445	Lock Nut
22	73430	Hammer Spring
23	73402A	Carbide Stylus (Standard)
24	73431	Stylus Spring
25	73428	Stylus Dampener
26	70055	Nose Cone O-Ring
27	73449	Nose Cone

Repair Service: Please note that you can send your TapWriter to Tapmatic for Service. Please see back page for details.

5. Accessories

TapWriter Torque Bar and Stop Arm Plate Installation

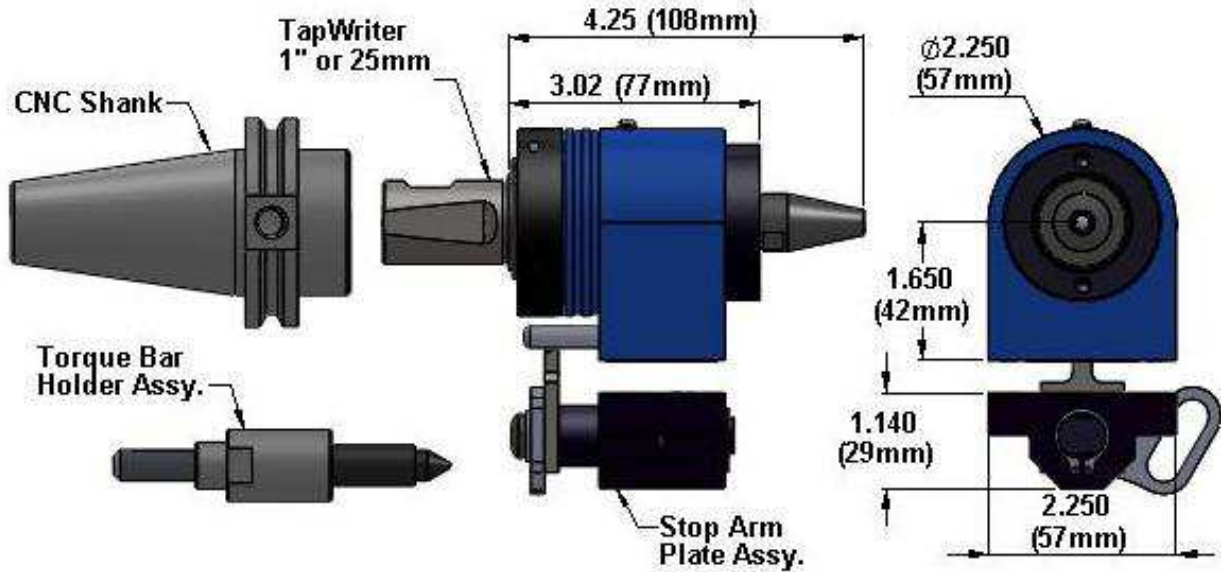

Stop Arm Plate Assembly 392552 includes a blank Stop Arm that can be modified.

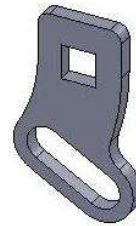

723420

Ready Made Stop Arms

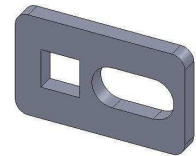

All Others

Part No.	Bolt Circle \varnothing Covered
723420	115mm to 133mm
723421	137mm to 149mm
723422	149mm to 171mm
723423	171mm to 193mm



Torque Bar Holder Assemblies

Teile Nr.	Bolzen Grösse	Teile Nr.	Bolzen Grösse
69383A	M6 x 1	69389A	5/16" – 18
69384A	M8 x 1.25	69390A	5/16" – 24
69385A	M10 x 1.5	69391A	3/8" – 16
69386A	M12 x 1.75	69392A	3/8" – 24
69387A	1/4" - 20	69393A	1/2" – 13
69388A	1/4" - 28	69394A	1/2" – 20

TAPMATIC

TapWriter Stop Block and Stop Arm Bar Installation

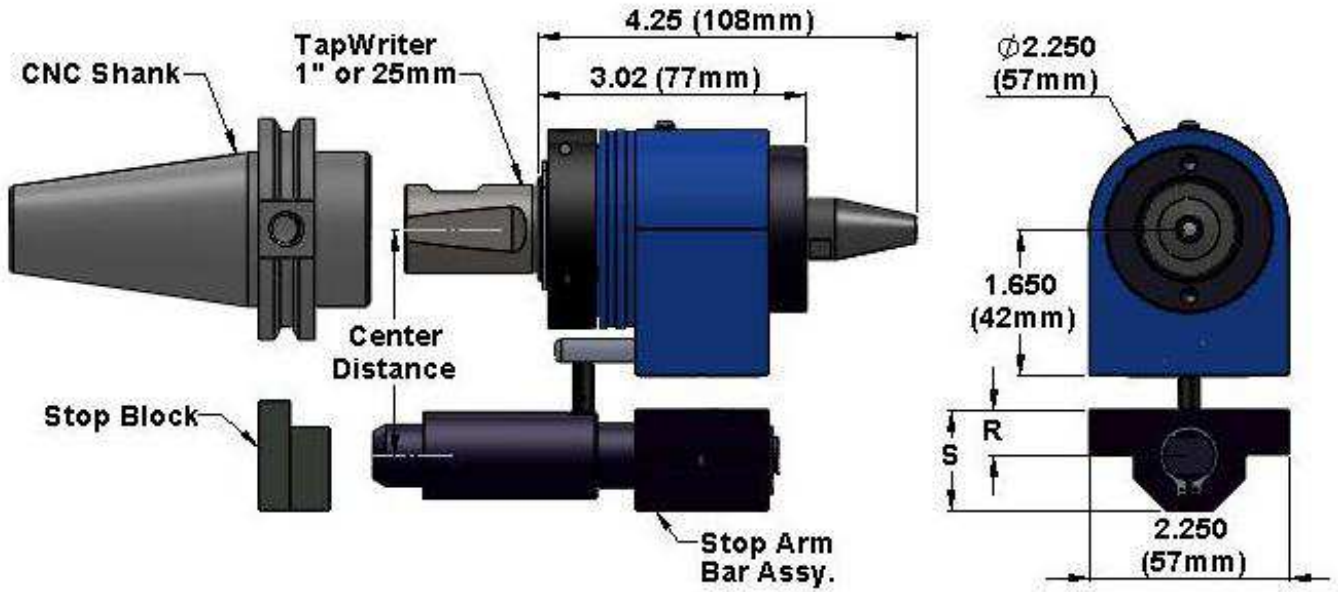

Stop Arm Bar Assemblies

Centre Distance	Part no.	R	S	42mm + S
55 mm	392555	13 mm	29 mm	71 mm
65 mm	392565	23 mm	39 mm	81 mm
80 mm	392580	38 mm	54 mm	96 mm

Standard Stop Block 36007

Bitte beachten Sie, dass TAPMATIC auch massgefertigte Stop Blocks für spezifische Maschinen anbietet.

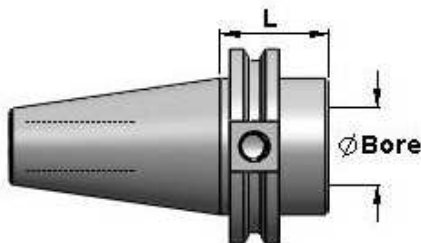
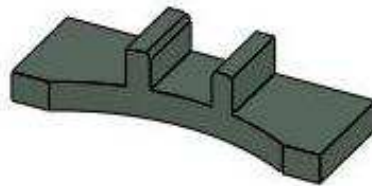

Part no.	Shank Size	Bore	L
23951	SK 40	1"	35 mm
S-242	SK 40	25 mm	35 mm
23953	SK 50	1"	35 mm
S-252	SK50	25 mm	35 mm
23952	BT 40	1"	35 mm
S-342	BT 40	25 mm	35 mm
23955	BT 50	1"	40 mm
S-352	BT 50	25 mm	40 mm

Additional Shanks also available.

TAPMATIC

Repair Service:

Through your local distributor or directly to

TIC AG
TAPMATIC International Corp.
Alte Rheinstrasse 29
CH-9451 Kriessern

To Expedite Repair: Enclose the following statement with your return shipment: "Authorization given to repair and return tool with out notification if total cost does not exceed 40% of the cost of a new tool." Tapmatic will repair the tool and invoice you through your local distributor.

Cost Notification: Tapmatic will send a cost notification to you, soliciting your approval before repairs are completed. Such a cost estimate will be charged with €/ \$ 30.00 or SFr 50.00. This amount will be fully credited against the invoice when the repair is carried out. If it is determined that a tool cannot be repaired, at the customer's request, Tapmatic will return the disassembled parts. We are not able to reassemble a tool using damaged or worn out parts.

Optional Return Procedure: Tools may also be returned for repair through your local Tapmatic Distributor. They will ship the tool to us and include instructions for the repair and return.

Should you have any more questions, please do not hesitate to contact us. We are pleased to answer your question:

+41 71 757 59 00

Or send us an E-Mail to

info@tapmatic.ch